

Upside

Assembly Instructions

Congratulations on your purchase of a new Upside Sit-to-Stand Desk!

Ready to put some movement into your day?

We know you want to get up and running as soon as possible, but before you dive right into setting up your desk, be sure to:

1. Grab a friend to help you with the lifting. They can also help you hold parts in place during assembly to make things a little easier.
2. Make sure you have all your parts and hardware, and gather the necessary tools and safety equipment.
3. Follow all the steps and synchronize your desk before using it.

That's it! Once you've got your desk assembled and synchronized, you'll be ready to enjoy the freedom to change position as you work anytime you want.

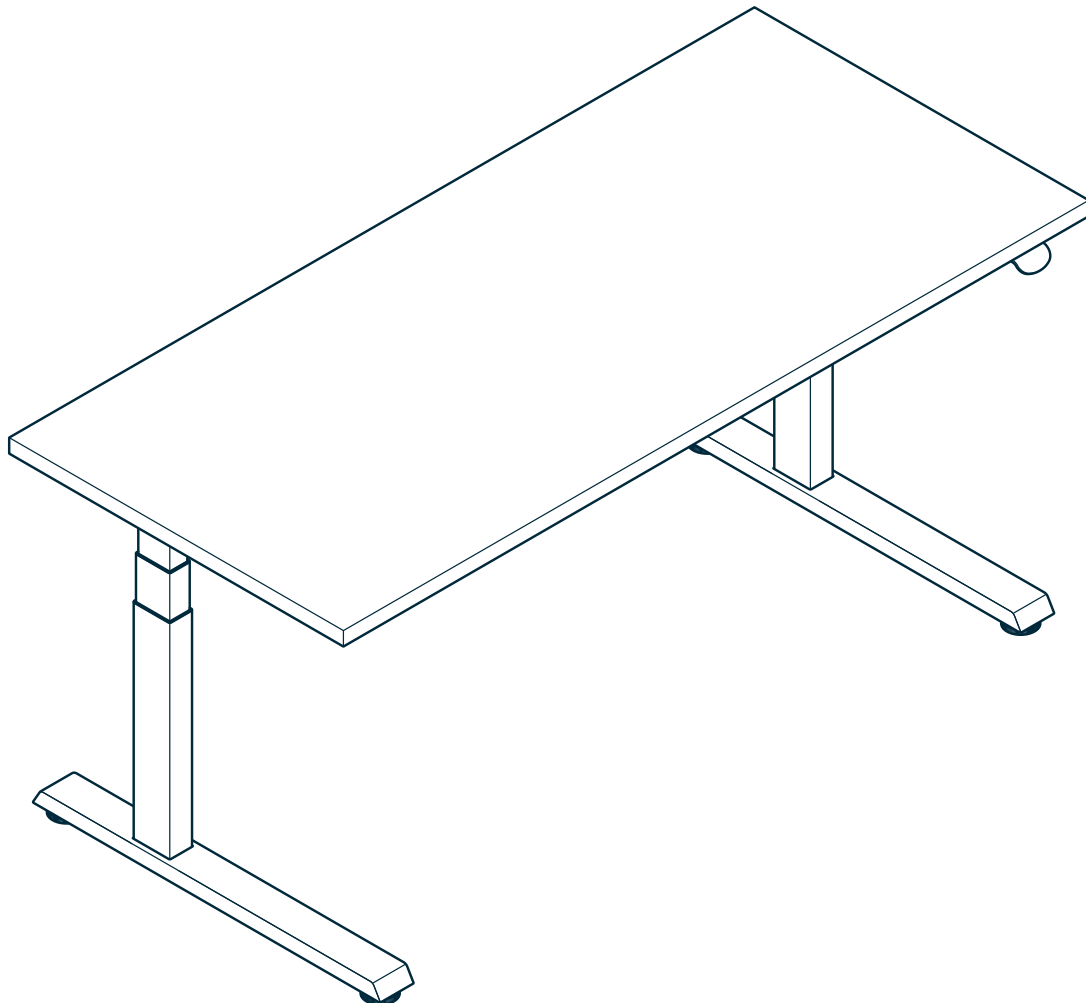

Important Safety Instructions

For use with Upside electric height-adjustable desks, 2-Leg For Commercial or Household Use
 This product conforms to UL962 and is certified to CAN/CSA C22.2 No. 68.

When using an electrical furnishing, basic precautions should always be followed, including the following:
 Read all instructions before using this desk.

DANGER - To Reduce the Risk of Electric Shock

1. Always unplug this furnishing from the electrical outlet before cleaning or servicing.

WARNING - To Reduce the Risk of Burns, Fire, Electric Shock, or Injury

1. Unplug from outlet before putting on or taking off parts.
2. Close supervision is necessary when this furnishing is used by, or near children, invalids, or disabled persons.
3. Use this furnishing only for its intended use as described in these instructions. Do not use attachments not recommended by the manufacturer.
4. Never operate this furnishing if it has a damaged cord or plug, if it is not working properly, if it has been dropped or damaged, or dropped into water. Return the furnishing to a service center for examination and repair.
5. Keep the cord away from heated surfaces.
6. Do not use outdoors.
7. Do not operate where aerosol (spray) products are being used or where oxygen is being administered.
8. To disconnect, turn all controls to the off position, then remove plug from outlet.

WARNING - Risk of Electric Shock, Fire, and Injury. Review the assembly instructions to confirm that the appropriate critical components and accessories are being used with the furnishing.

9. Connect this furnishing to a properly grounded outlet only. See grounding instructions.

Electrical Rating

120V, 60Hz, 6.25A for Upside Standard 2 leg desks
 120V, 60Hz, 6A for Upside Value 2 leg desks

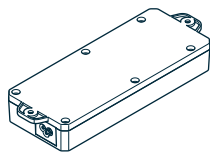

Save These Instructions

This product must be grounded. If it should malfunction or breakdown, grounding provides a path of least resistance for electric current to reduce the risk of electric shock. This product is equipped with a cord having an equipment-grounding conductor and a grounding plug. The plug must be plugged into an appropriate outlet that is properly installed and grounded in accordance with all local codes and ordinances.

DANGER - Improper connection of the equipment-grounding conductor can result in a risk of electric shock. Check with a qualified electrician or serviceman if you are in doubt as to whether the product is properly grounded. Do not modify the plug provided with the product—if it will not fit the outlet, have a proper outlet installed by a qualified electrician.

This product is for use on a nominal 120-volt circuit and has a grounding plug that looks like the plug illustrated in Figure 1. Make sure that the product is connected to an outlet having the same configuration as the plug. No adapter should be used with this product.

Maximum Load rating including surface: 250 lbs

Figure 1

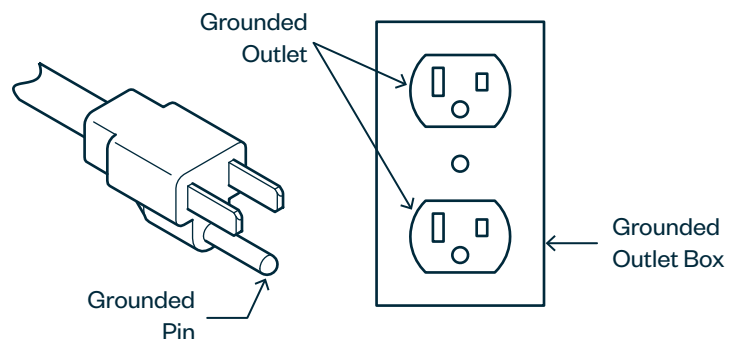

Tools Required

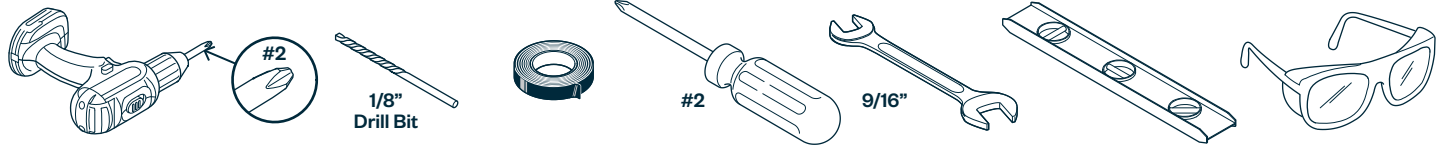

Assembly Overview

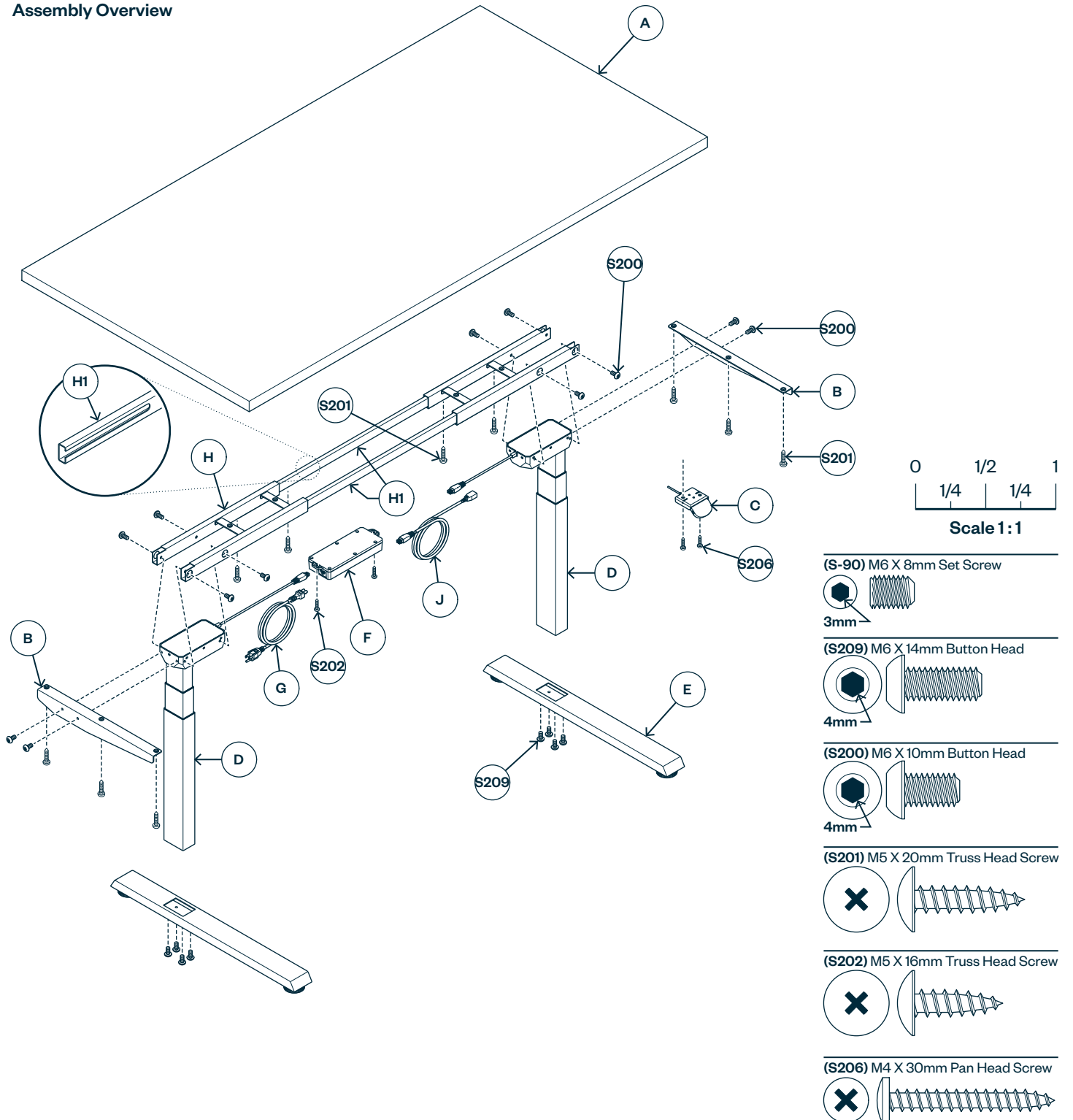

(A) Desk Top

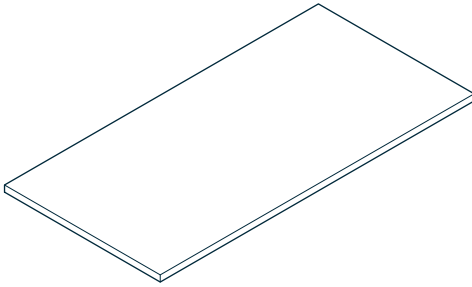

(B) End Brackets

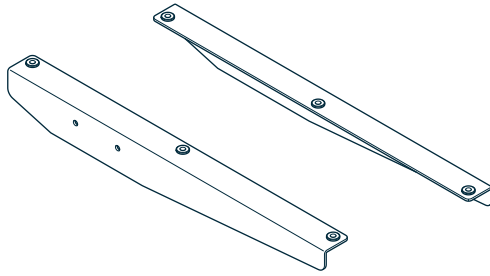

(C) Paddle Handset

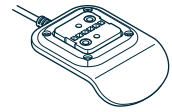

(D) Leg Column

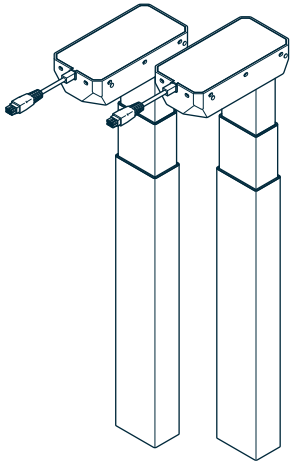

(E) Foot

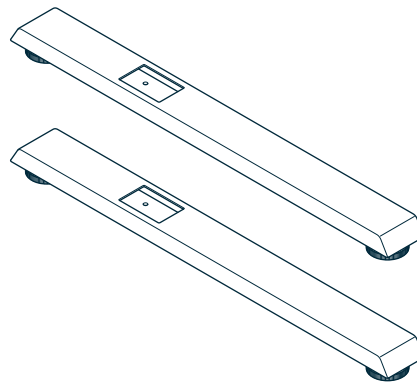

(F) Control Box

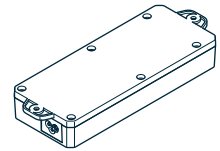

(G) Power Cord

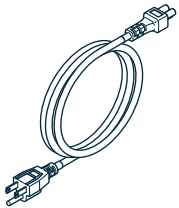

(H) Frame and (H1) Rails

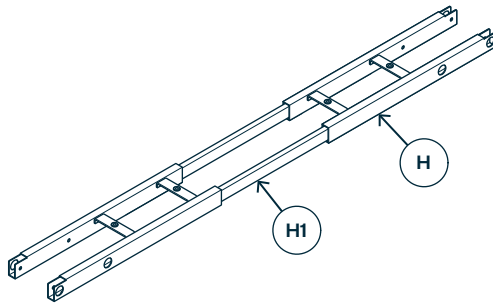

(J) Motor Extension Cable

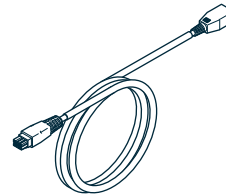

(K) Cable Clips - Qty. 10

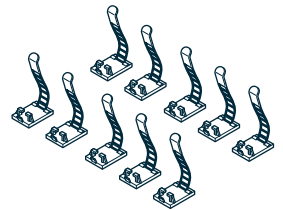

(S200)



(S209)

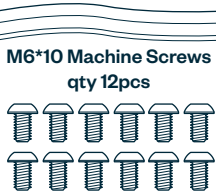

(S209)

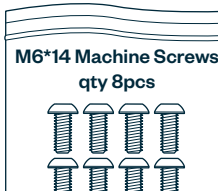

(S201)

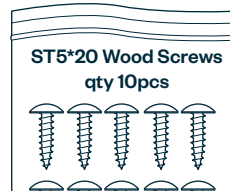

(S202)



(S-90)



1

Pull frame (H) off rails (H1) as shown

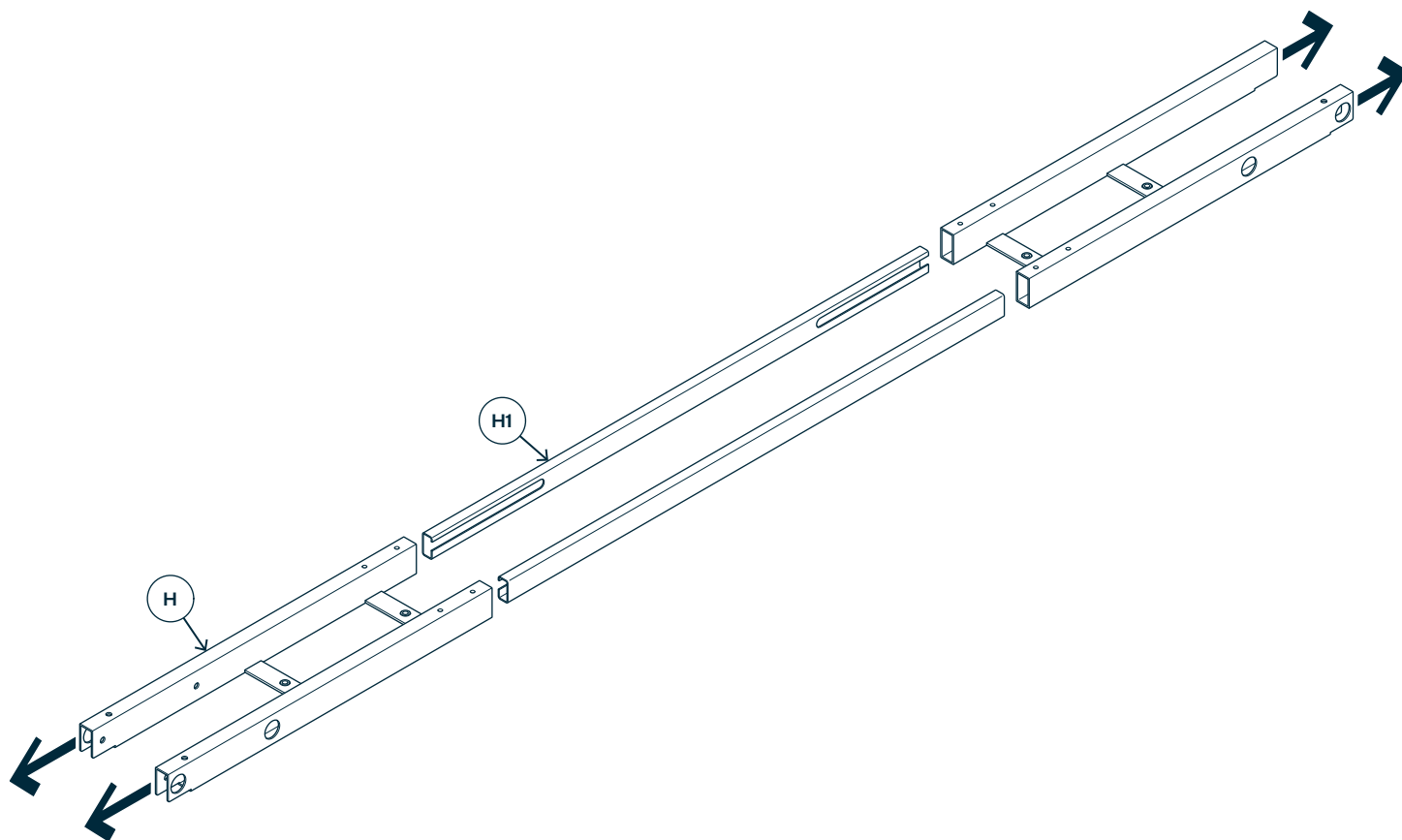

2

Attach column (D) to frame (H) - Slightly lift column to align holes

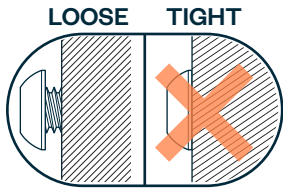

4 Qty.

(S200) M6 X 10mm Button Head

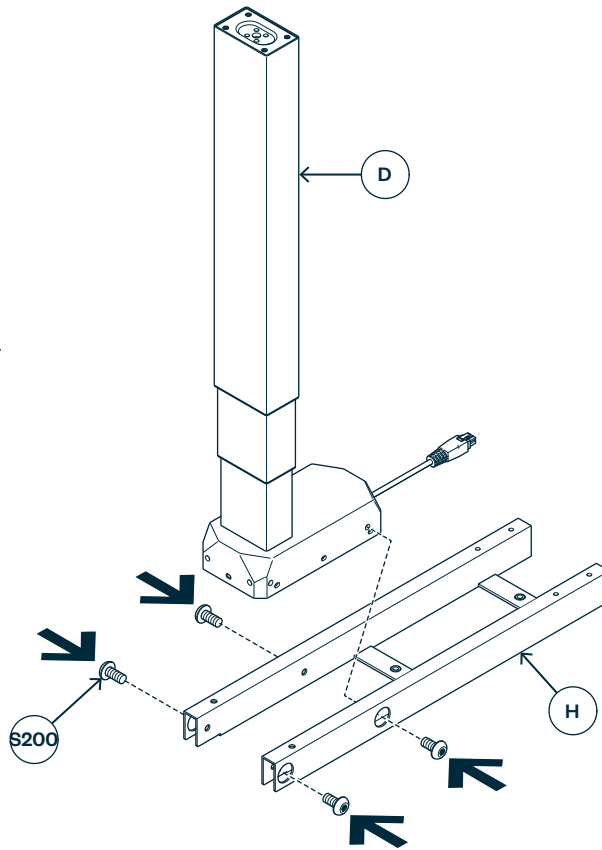
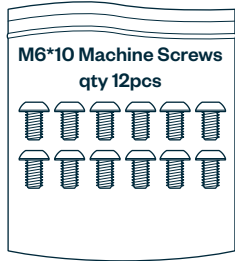
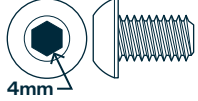

Important
Install screws (S200)
LOOSELY

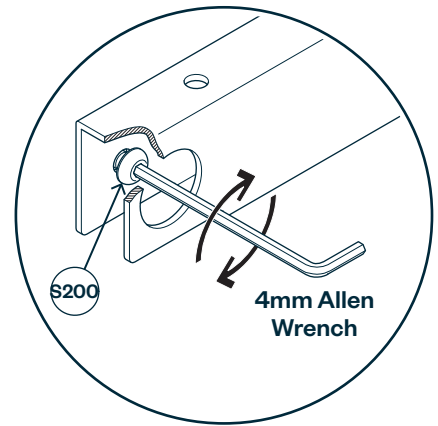

3

Repeat 2nd step 2 to attach 2nd column (D) to frame (H)

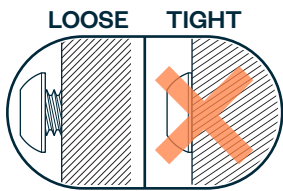

4 Qty.

(S200) M6 X 10mm Button Head

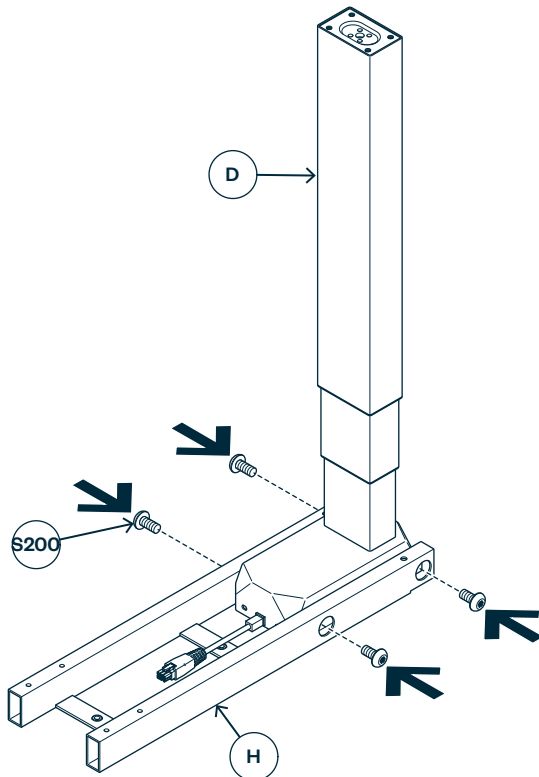
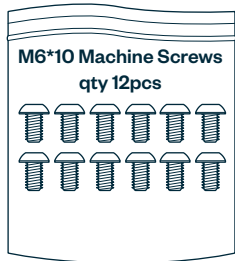
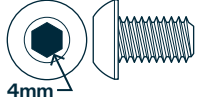

Important
Install screws (S200)
LOOSELY

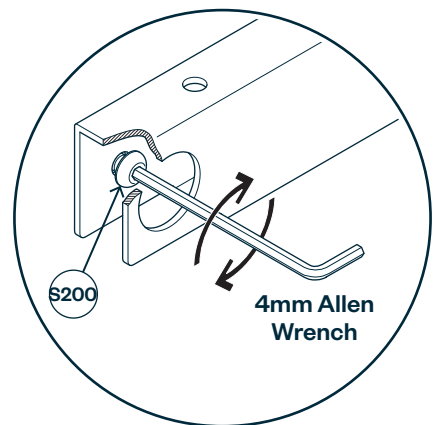

4

Attach bracket (B) to column (D) - Tilt column (D) and frame (H) slightly to align holes

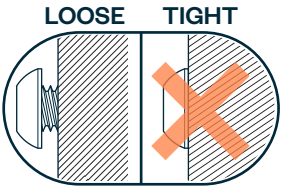

2 Qty.

(S200) M6 X 10mm Button Head

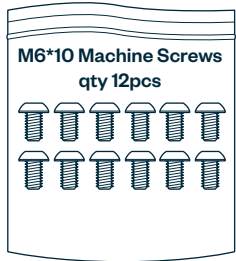
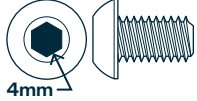

Important
Install screws (S200)
LOOSELY

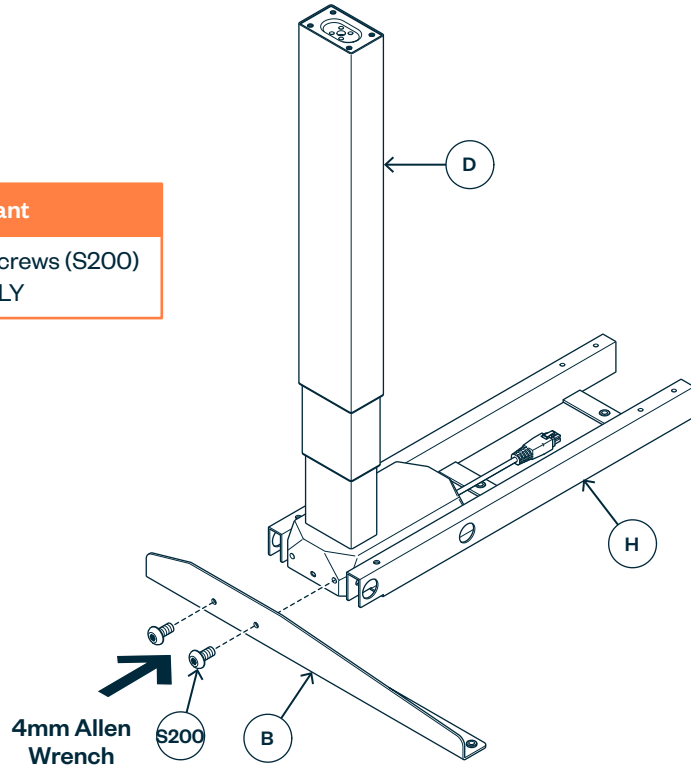

5

Repeat step 4 to attach 2nd bracket (B) to column (D)

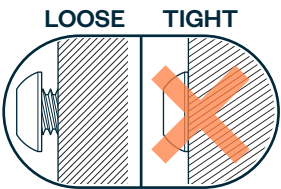

2 Qty.

(S200) M6 X 10mm Button Head

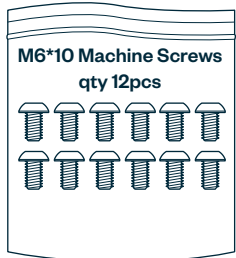
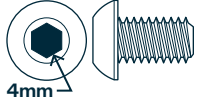

Important
Install screws (S200)
LOOSELY

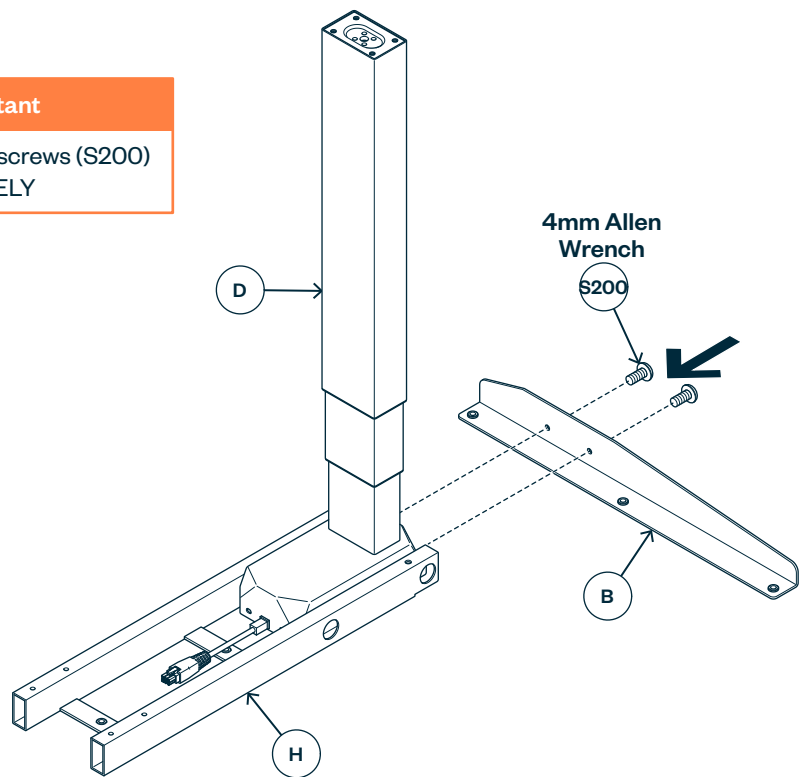

6 Tighten all 6 screws (S200)

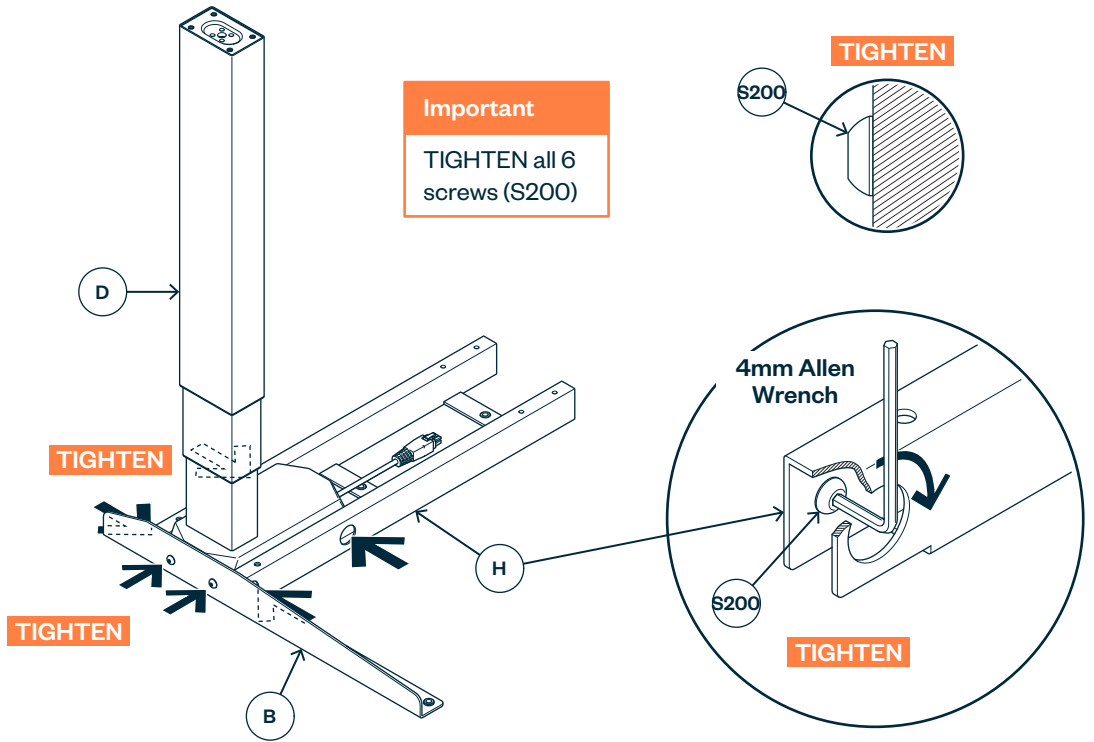

7 Repeat for other side and tighten all 6 screws (S200)

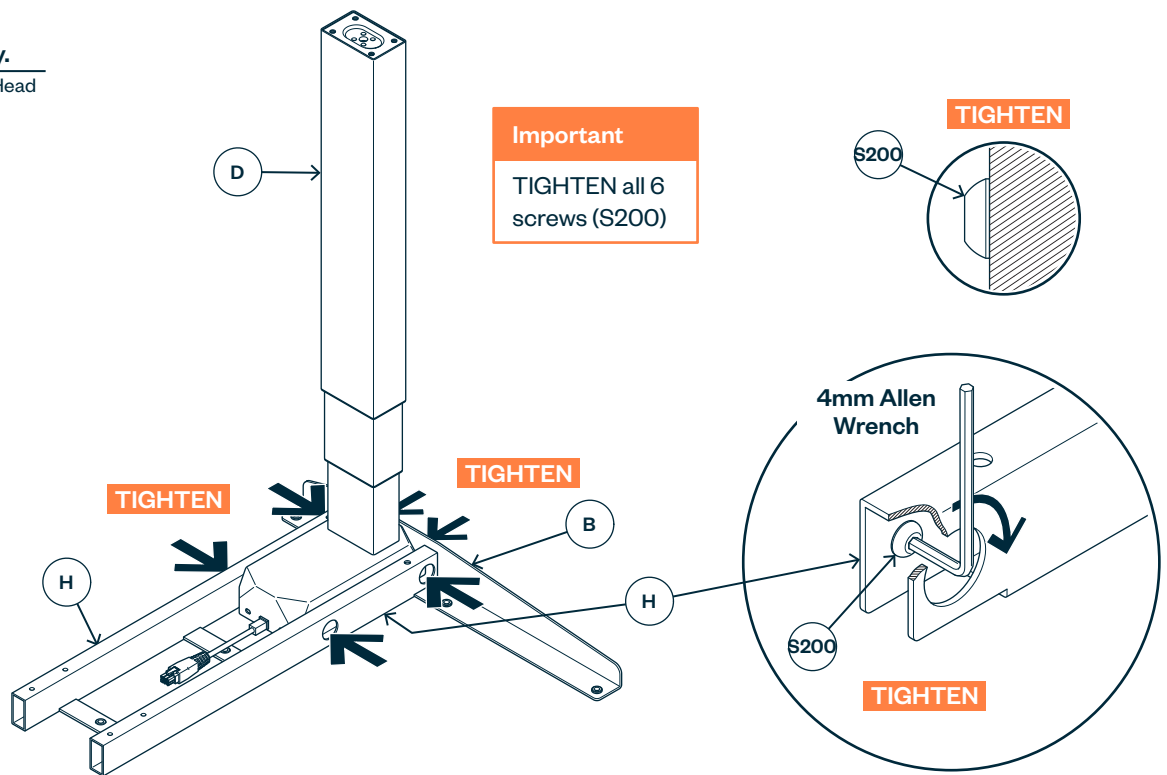
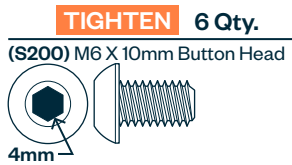

8

Slide rails (H1) and frame (H) together

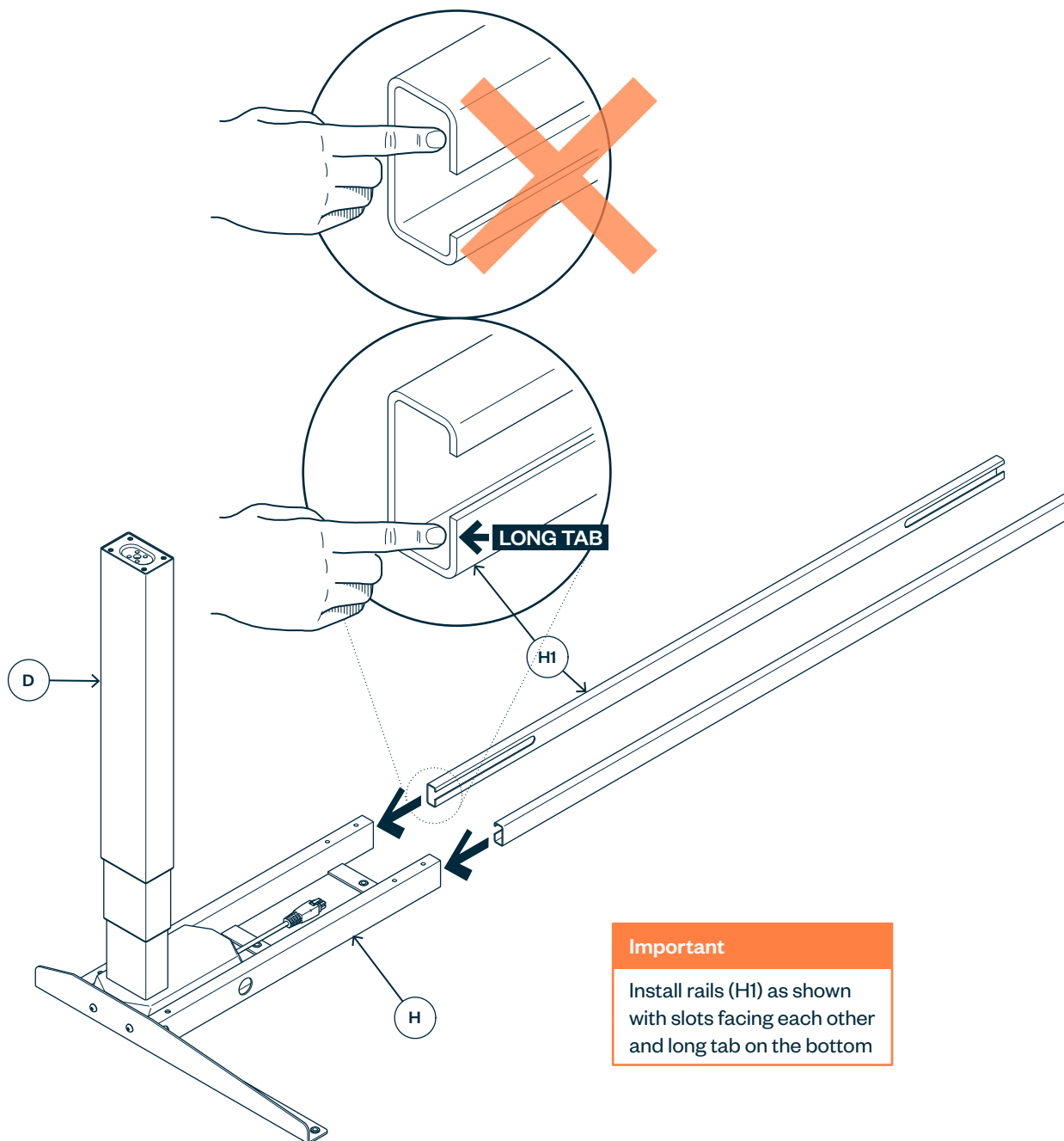

9 Repeat step 8 for other side and slide frame (H) onto rails (H1)

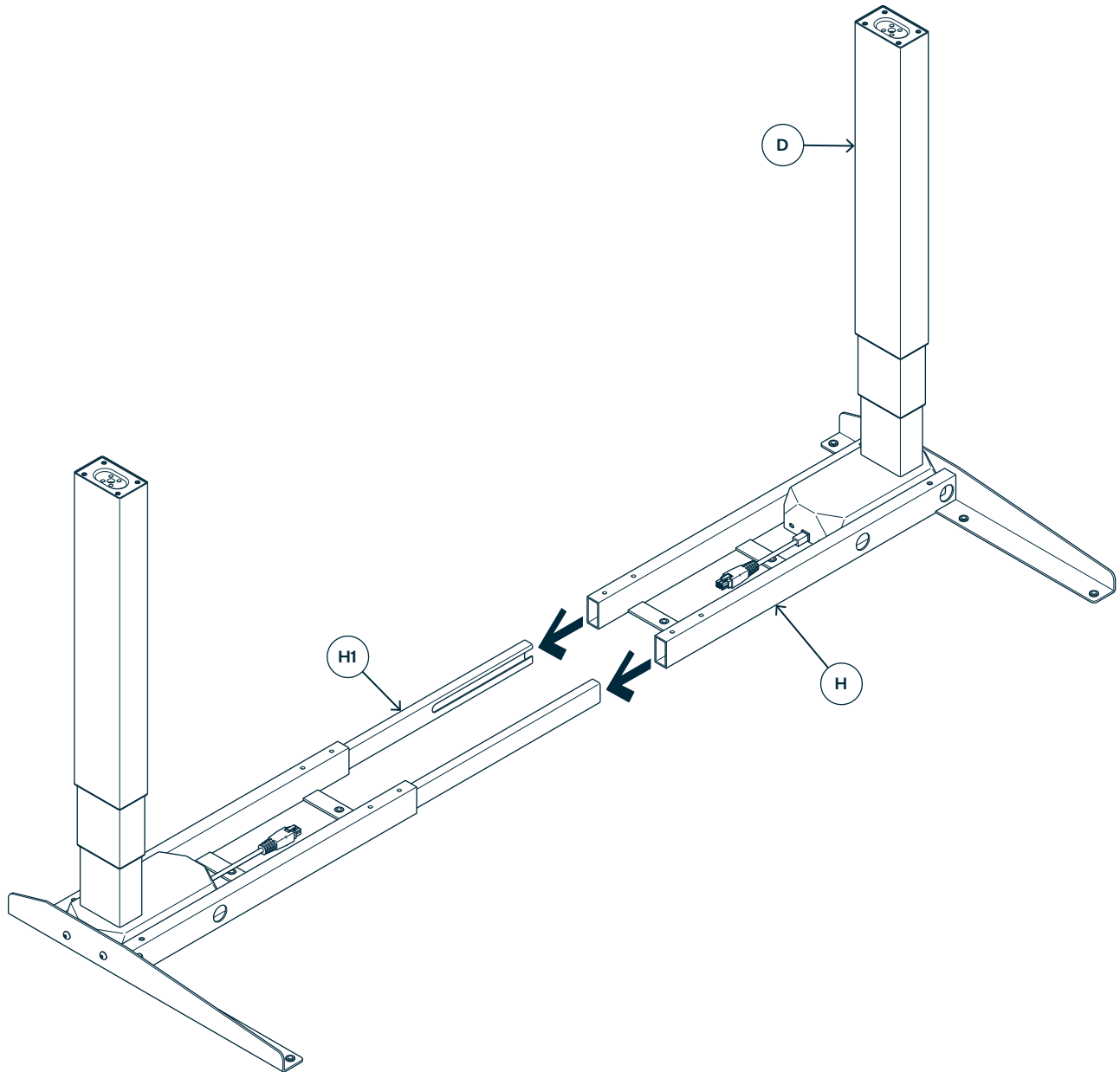

10 Attach frame (H) to desk top (A) - Align holes in brackets (B) with holes in desk top (A)

6 Qty.

(S201) M5 X 20mm Truss Head Screw

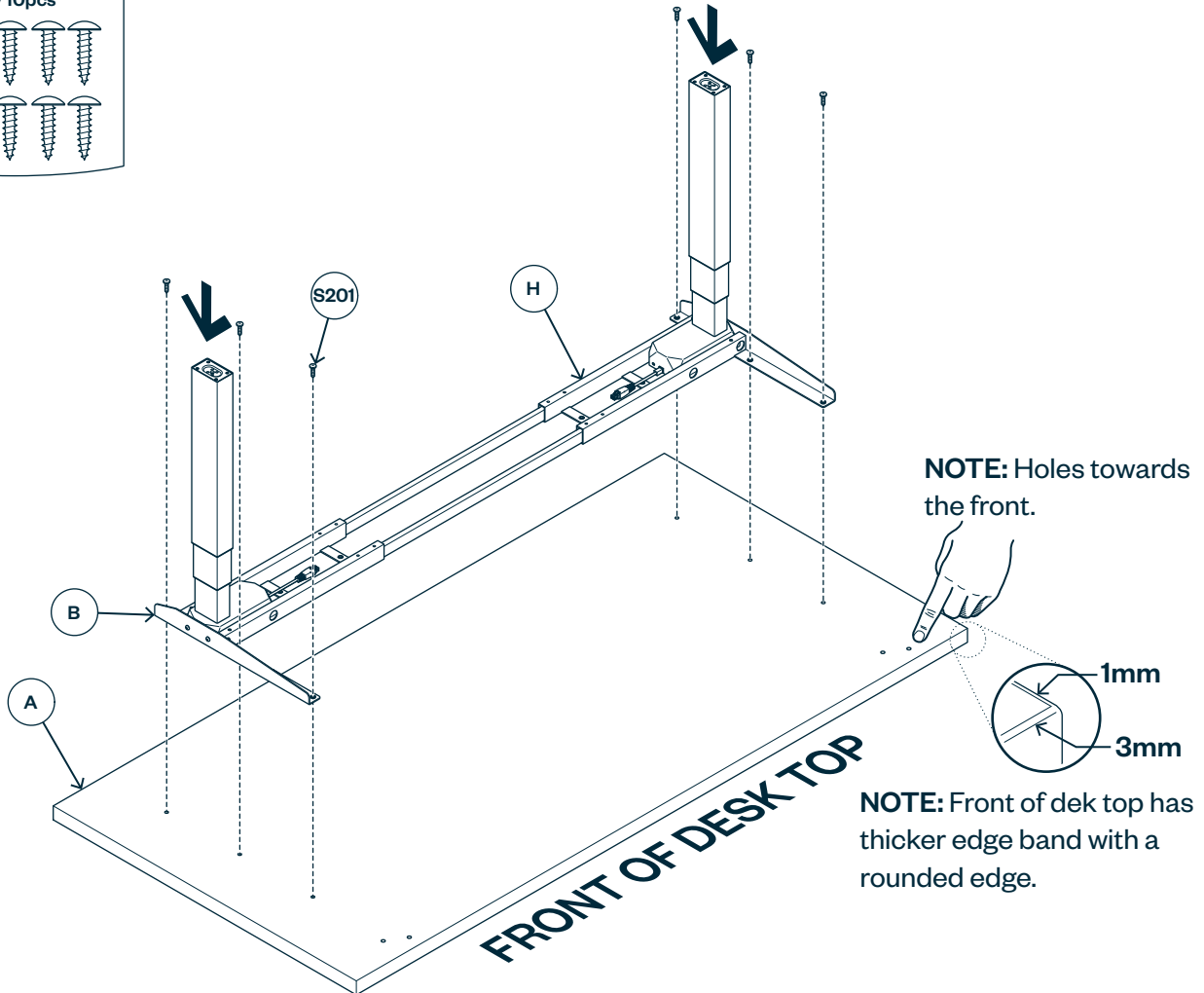
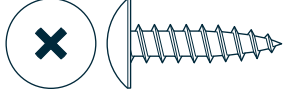

11 Drilling may be required to start screws (S201)

NOTE: You may need to drill 1/4" deep holes to start the screws.

4 Qty.
(S201) M5 X 20mm Truss Head Screw

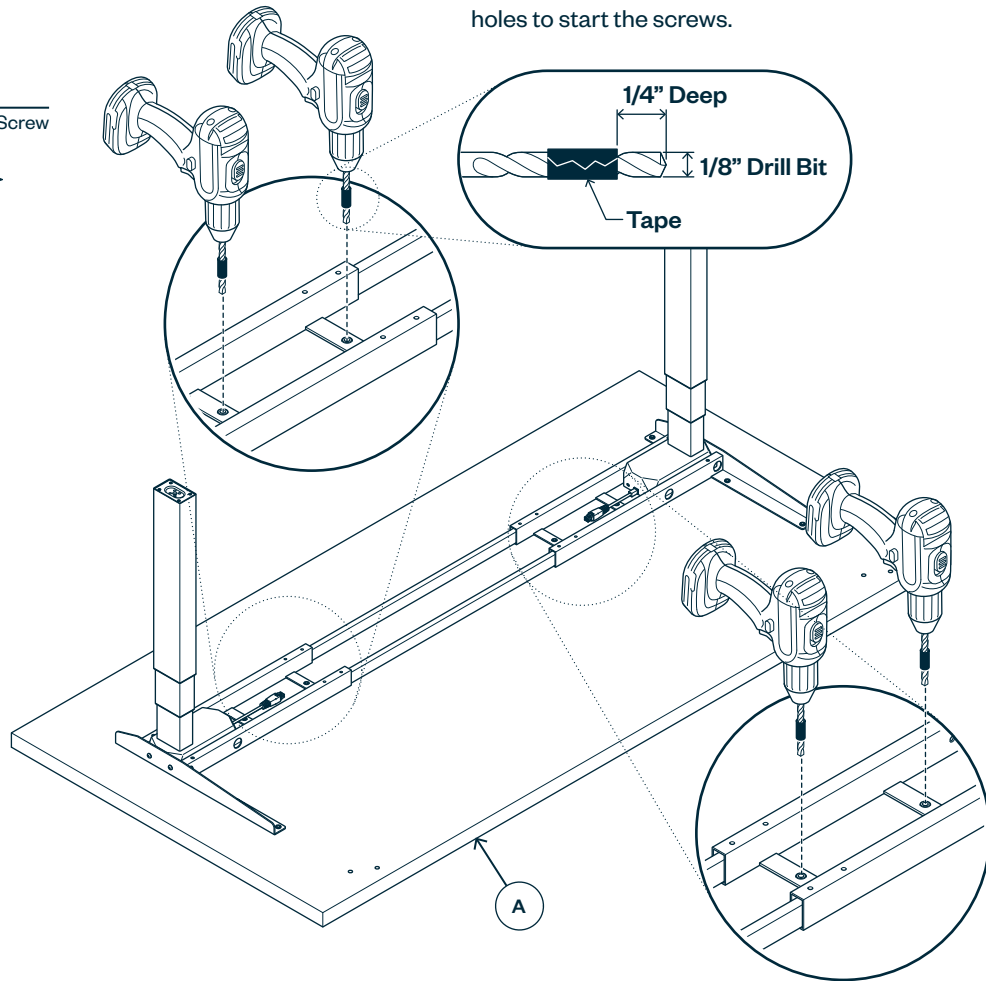
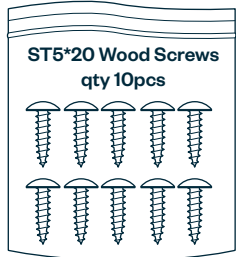
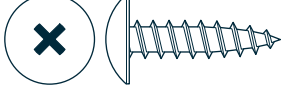

12 Install 4 screws (S201) as shown

4 Qty.
(S201) M5 X 20mm Truss Head Screw

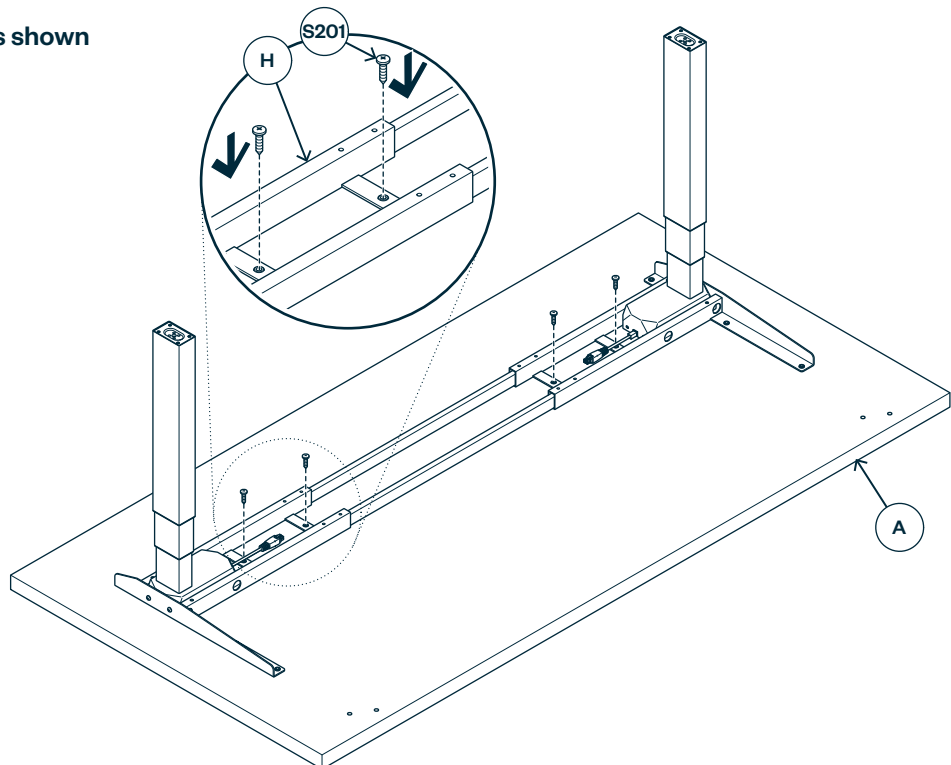
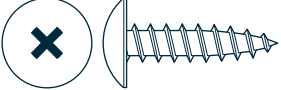

13 Install 8 set screws (S-90) as shown

8 Qty.
(S-90) M6 X 8mm Set Screw

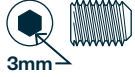

Important

Make sure set screw (S-90) engage rails (H1).

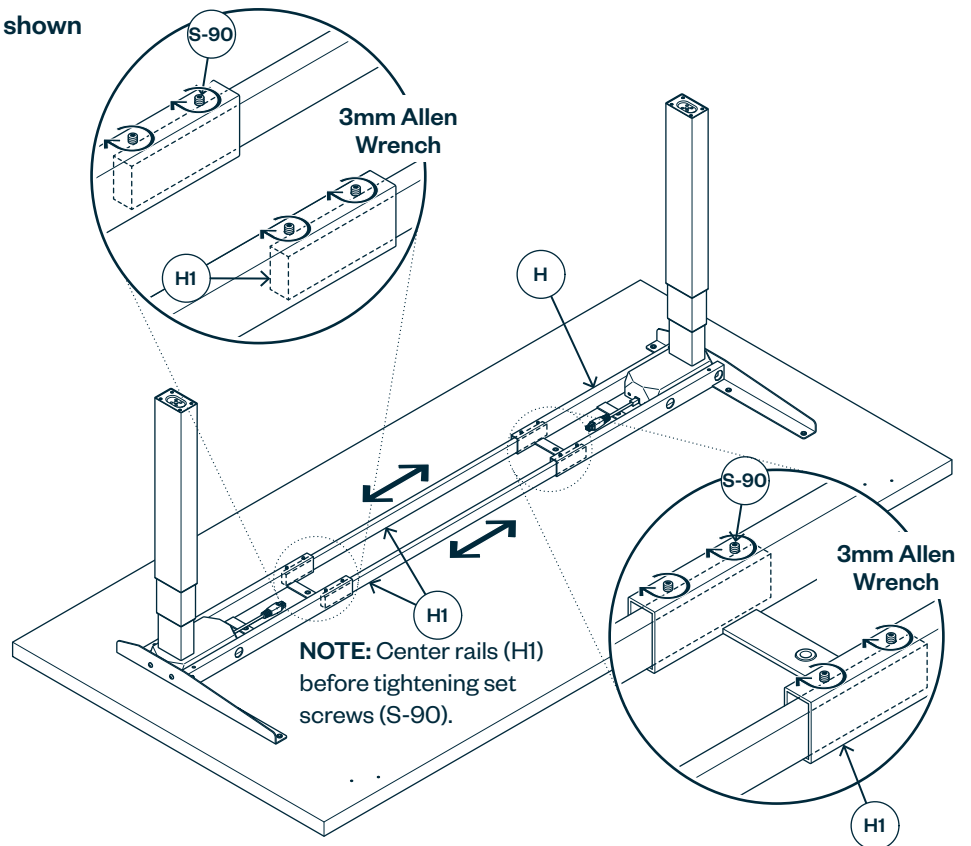

14 Install feet (E) as shown

8 Qty.
(S209) M6 X 14mm Button Head

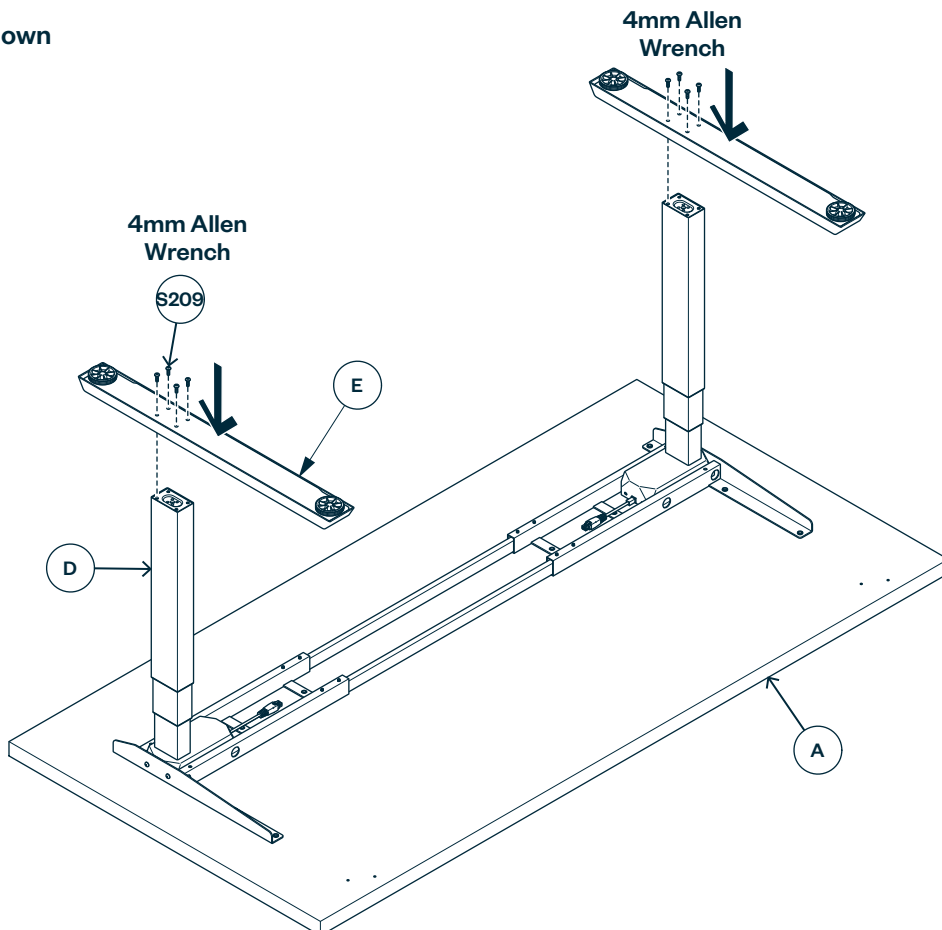
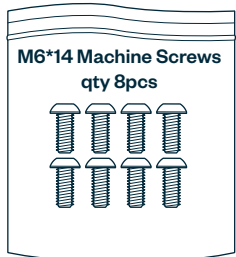
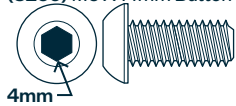

CASTER INSTALLATION - OPTIONAL

15 Remove foot pads (D1) as shown

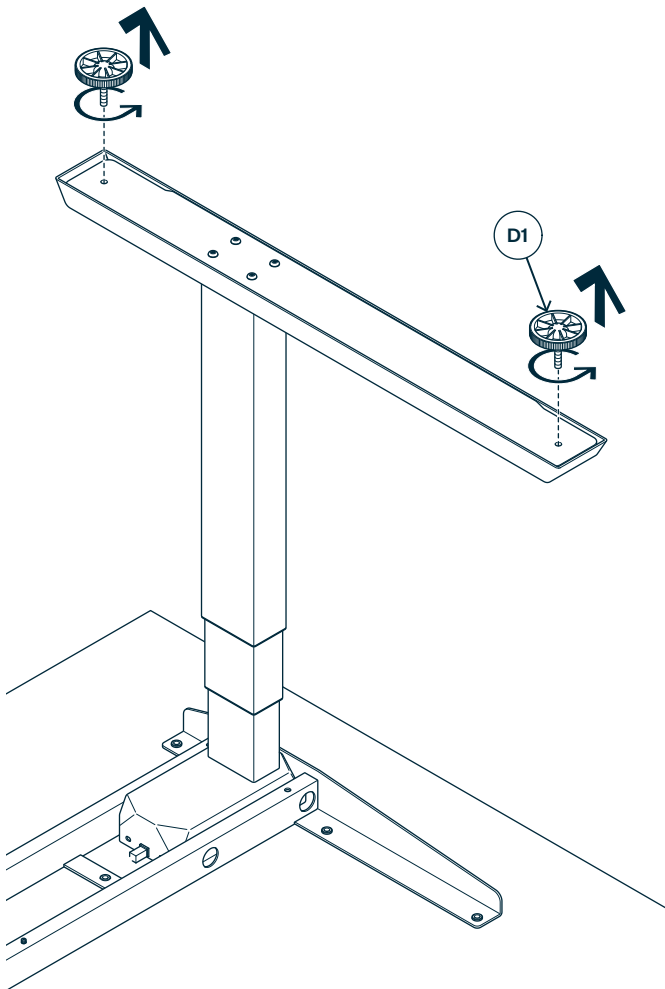

16 Insert casters (D2) and tighten with wrench as shown

NOTE: Casters are optional and ordered separately.

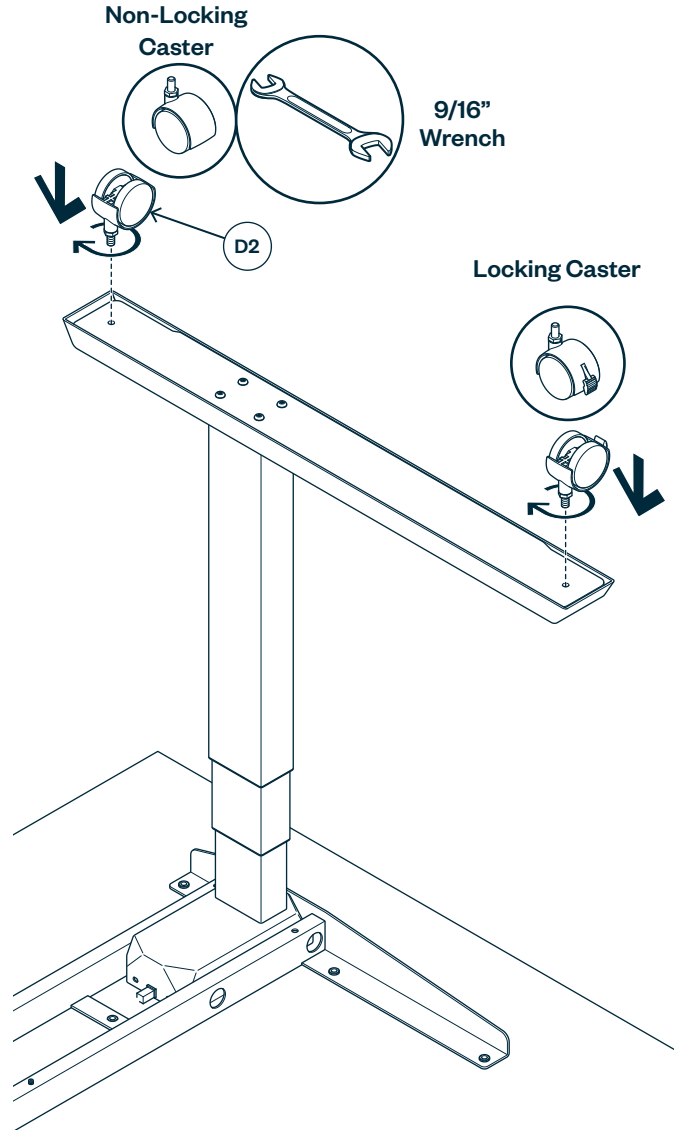

17 Plug cable (D) into control box (F) as shown

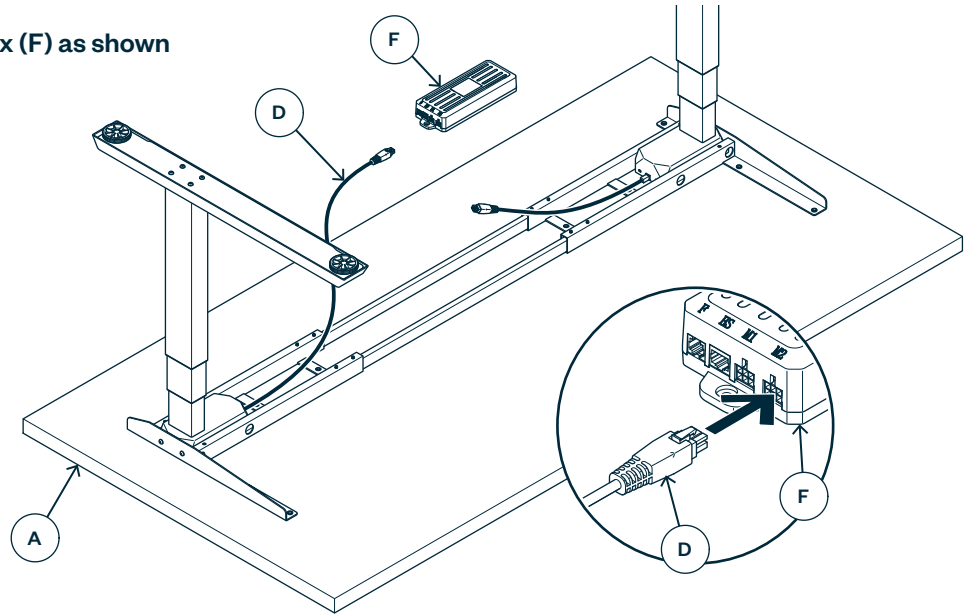

18 Install control box (F) as shown

2 Qty.
(S202) M5 X 16mm Truss Head Screw

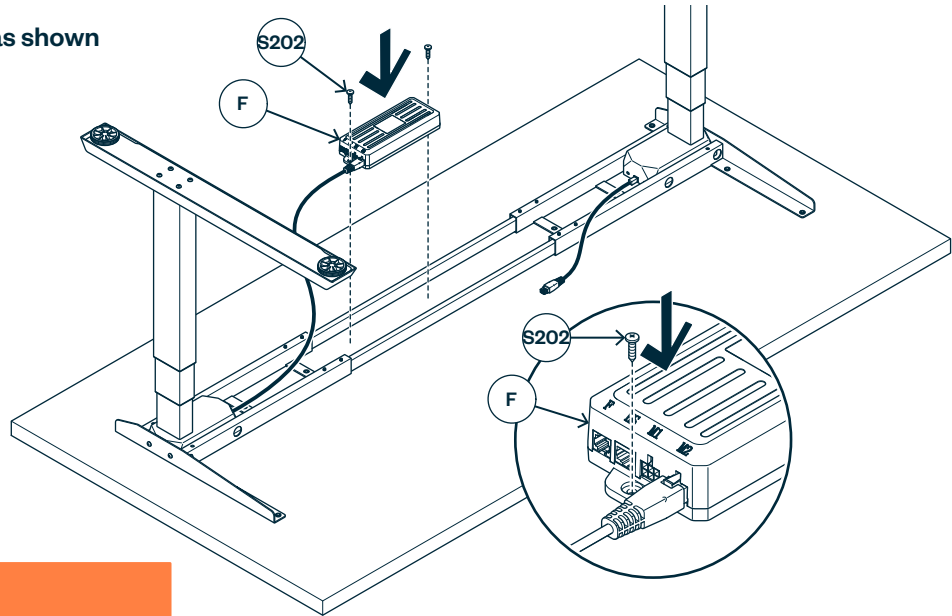
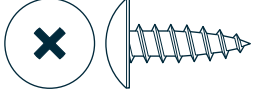

Important
Make sure control box (F) is firmly attached to the worksurface

NOTE: For frame (H) less than 46 inches wide mount control module (F) outside of frame (H) as shown below.

52" AND LARGER

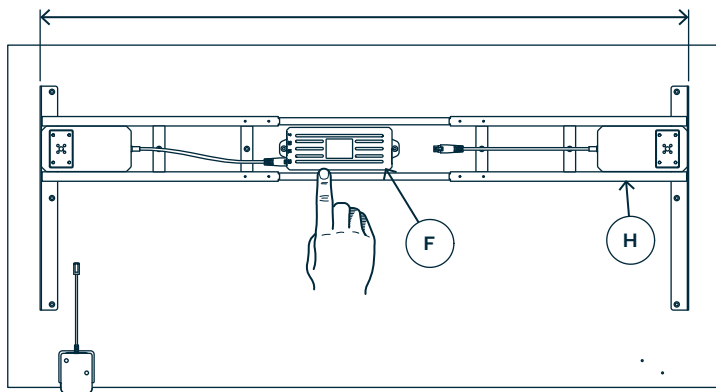

OR

46" AND SMALLER

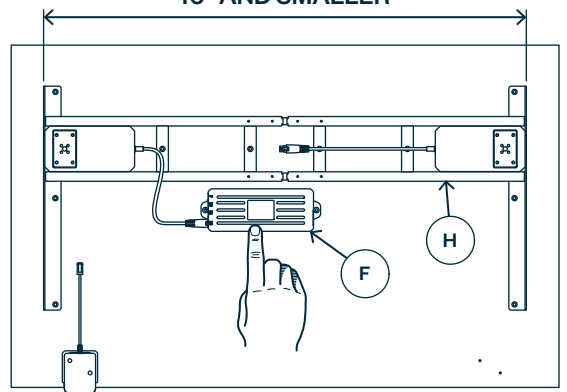

19 Plug motor extension cable (J) into control box (F) and column (D) as shown

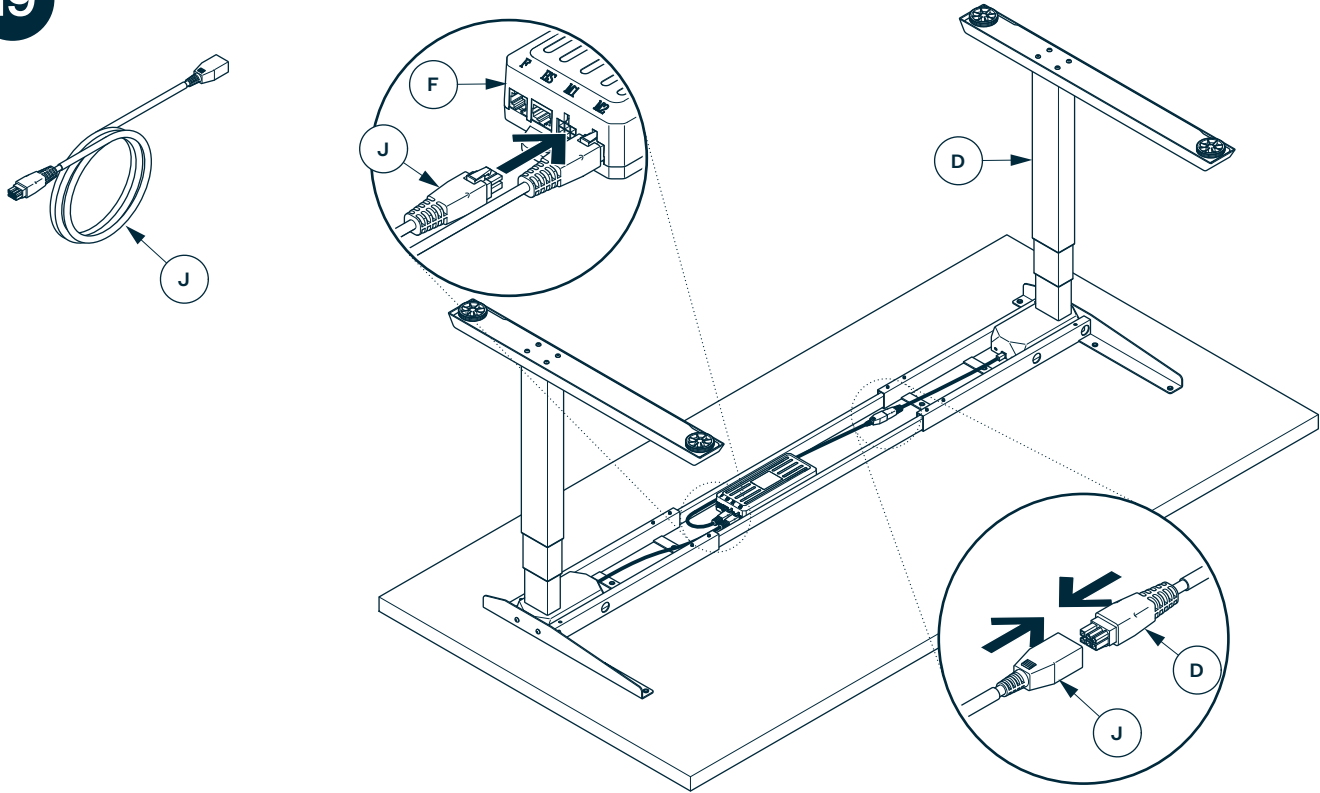

20 Plug power cable (G) into control box (F) as shown

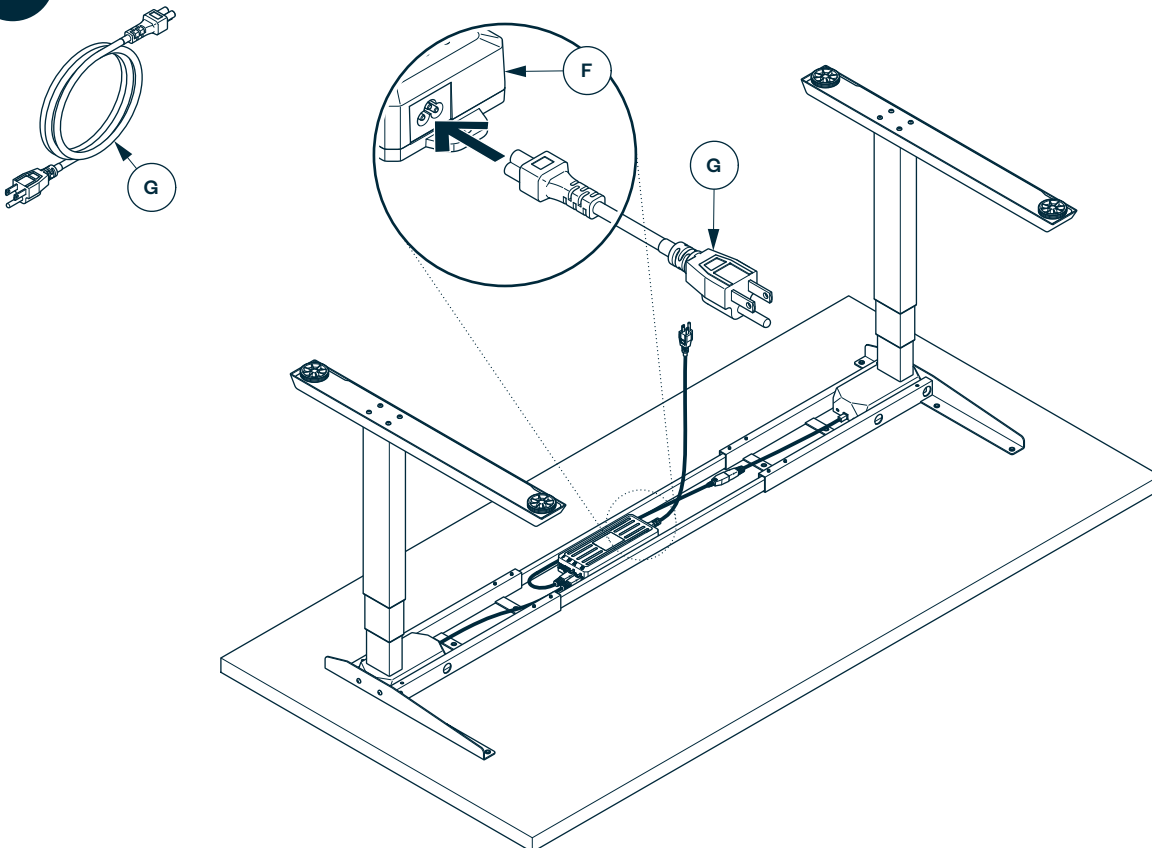

21 Install paddle handset (C) with hand screwdriver ONLY

#2 Screwdriver

NOTE: Paddle screw (S206) must be installed straight and fully seated. Crooked or partial installation of screws (S206) may interfere with the paddle (C) performance (both standard and programmable).

2 Qty. (S206) M4 X 30mm Pan Head Screw

STOP! DO NOT USE DESK UNTIL ALL STEPS AND SYNCHRONIZATION HAVE BEEN COMPLETED

22 Install cable clips (K) as shown

STOP! DO NOT USE DESK UNTIL ALL STEPS AND SYNCHRONIZATION HAVE BEEN COMPLETED

23

With a helper, flip desk onto its feet

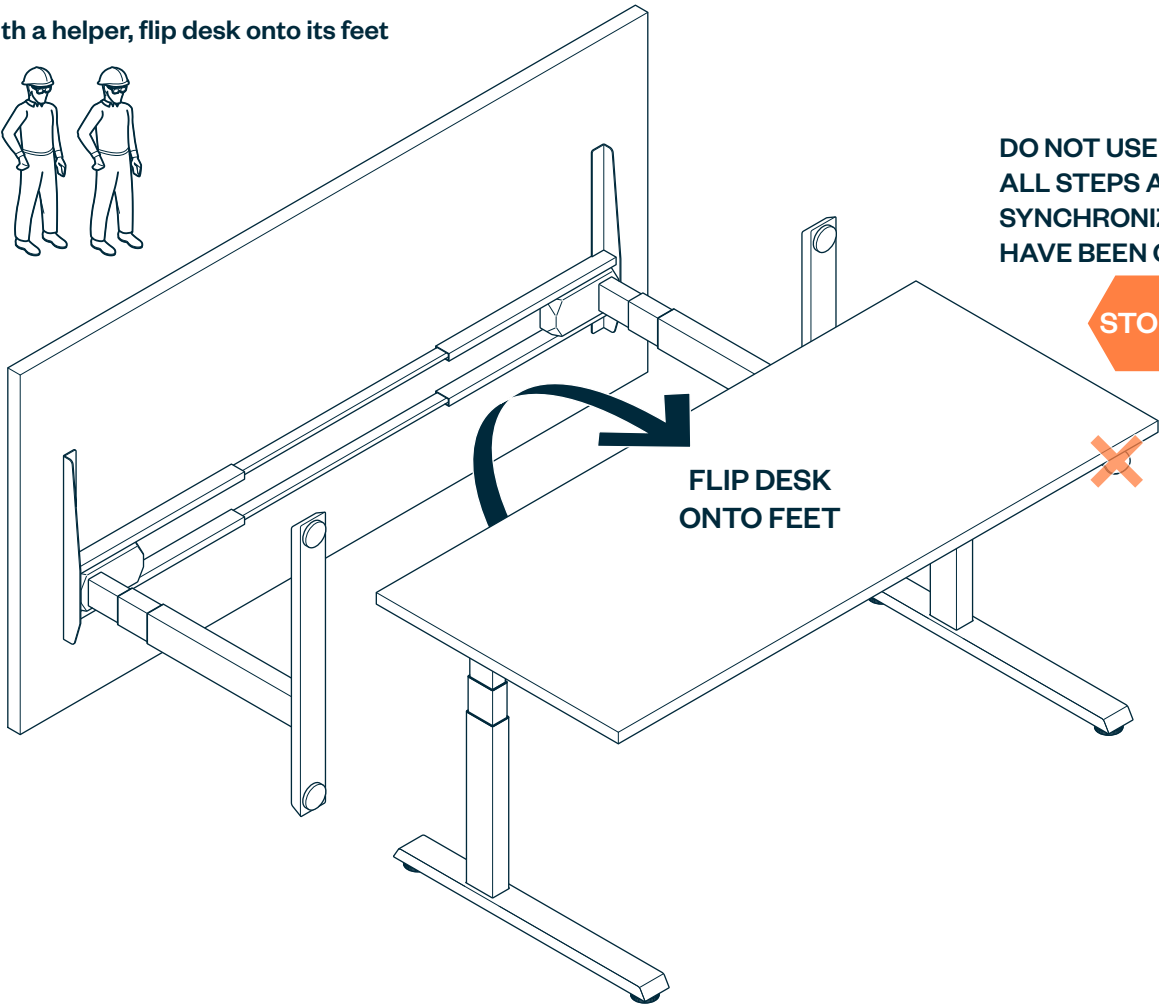

DO NOT USE DESK UNTIL ALL STEPS AND SYNCHRONIZATION HAVE BEEN COMPLETED



FLIP DESK ONTO FEET

24

Level desk as shown



DO NOT USE DESK UNTIL ALL STEPS AND SYNCHRONIZATION HAVE BEEN COMPLETED

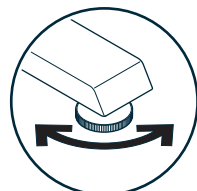
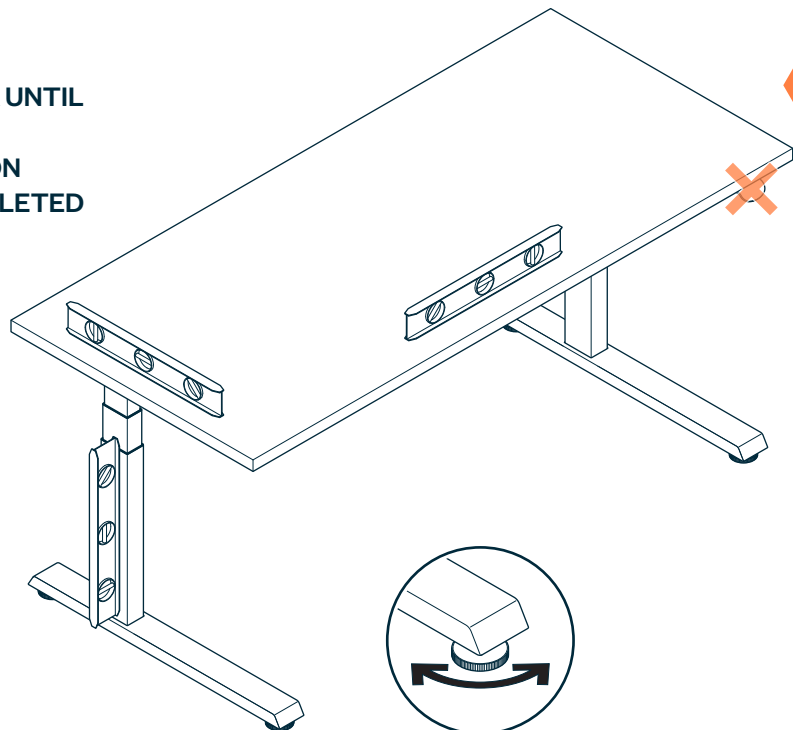
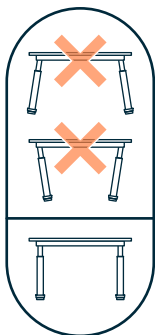

SYNCHRONIZE DESK

25 Lower desk all the way down using paddle handset (C)

Important
Prior to first use, synchronize the motors in the columns (D)

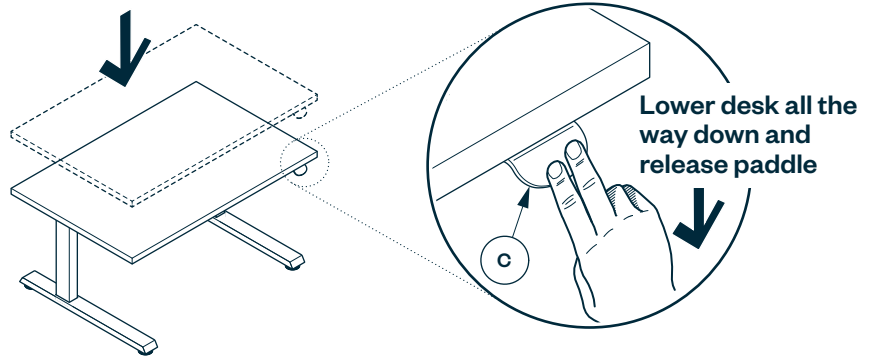

- If table is already at lowest position skip to step 26.
- If table will not go up or down, skip to step 26 then in step 27; hold down paddle until desk reaches its lowest point and moves up slightly.
- If table will go down but not up, step 26 is already complete, skip to step 27.

26 Press paddle handset (C) again and hold for 15 seconds, then release

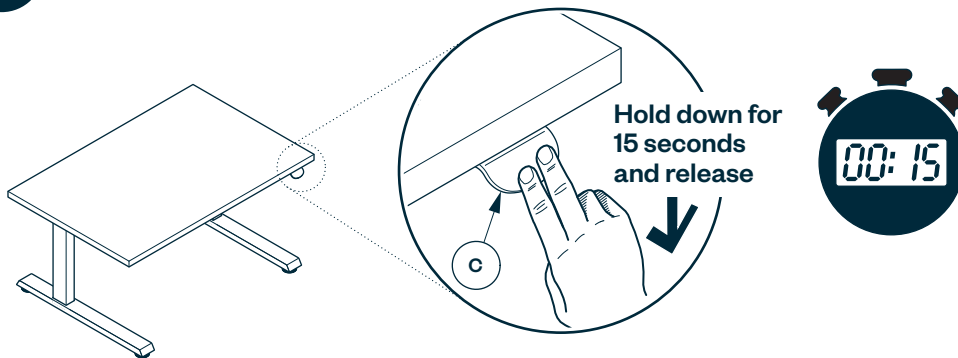

NOTE: Desk must be synchronized prior to first use, monthly to maintain synchronization, every time power is interrupted, and any time a cable, plug or paddle is plugged into the control box.

27 Again press and hold down paddle handset (C) until it slightly moves up

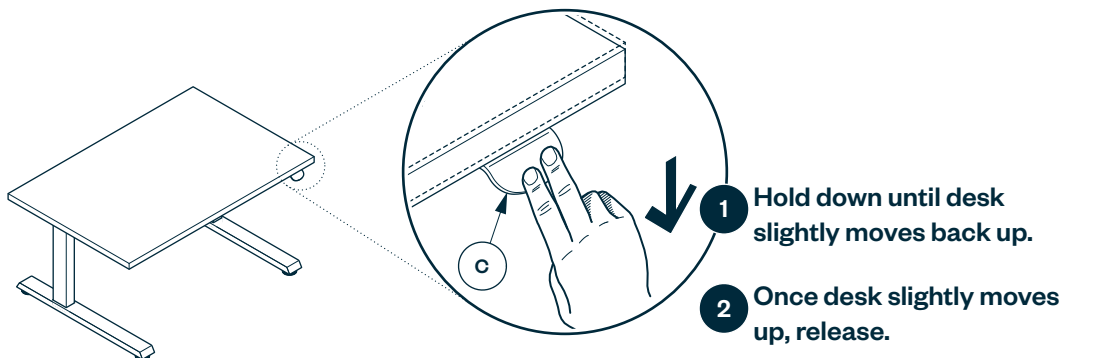

- If the process has been completed and the desk did not move up slightly when synchronization was complete, wait 30 minutes and try again, holding the paddle for 20 seconds instead of 15.
- If it still does not reset, unplug desk for 30 minutes, then plug it back in and go through steps 24-26 again.

SYNCHRONIZATION INTERVALS**28**

Be sure to synchronize your desk as noted below to keep it calibrated and functioning properly.

- 1) Before first use**
- 2) After any cables/cords are disconnected/reconnected or after servicing any component (swapping out paddles, disconnecting/reconnecting the cables/cords, etc.)**
- 3) After any interruption in power or loss of power (or any time the power cord is unplugged from the outlet and plugged back in)**
- 4) Monthly to maintain optimum desk performance**