

## Cable Base Cable Retractor

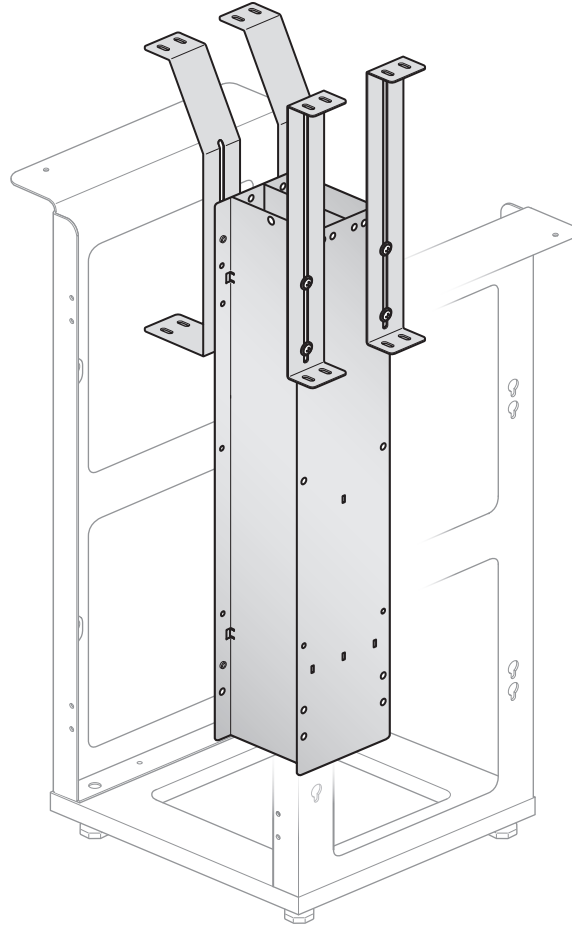

Cable Base Cable Retractor

### Overview

- Provides gravity wheel to retract cable into individual chute.
- Mounts to bottom of table.
- Provides up to 34" of cable travel.

## Cable Base Cable Retractor

### General Specifications

- Round gravity wheel pulls cable back into 1.5" x 4" chute
- Works with separately specified HDMI, VGA, 3.3mm audio, Cat 6, or Display Port cables
- Recommend 10 foot or longer cables be used with cable retractor
- Mounting brackets allow screws to fasten retractor to bottom of table
- Chutes must be installed vertically to allow gravity to retract cables
- Available in 2, 4 or 6 chute configurations

### Applicable Codes

- Cable retractor contains low voltage cables which must be installed in accordance with the National Electrical Code (NEC), the Canadian Electrical Code (CEC) and local electrical codes

### Complementary Products

- Haworth Workware® interface, flush mount power module, Flip Top power module equipped with Cable bays. Planes® Conference Table Column Base, Planes® Cable Base or flush mount module with Planes® cable Base surrounding retractor

### Typical Configuration

- Mounted to table worksurface below Workware® interface or flush mount module with Planes® cable Base surrounding retractor

