

BuzziPleat LED

BuzziSpace | 13&9 Design | 2017

The traditional craft of hand pleating is applied to freely construct BuzziPleat LED. Creating the architectural folds takes more than 140 minutes of steady hand and eye coordination, and results in a maximized surface area that delivers exceptional acoustic and lighting performance. Choose from medium or large sizes in either Edel or Ripple patterns.

HAWORTH collection

BuzziPleat LED

BuzziSpace | 13&9 Design | 2017 | Made in the United States



Medium Pendant, Ripple

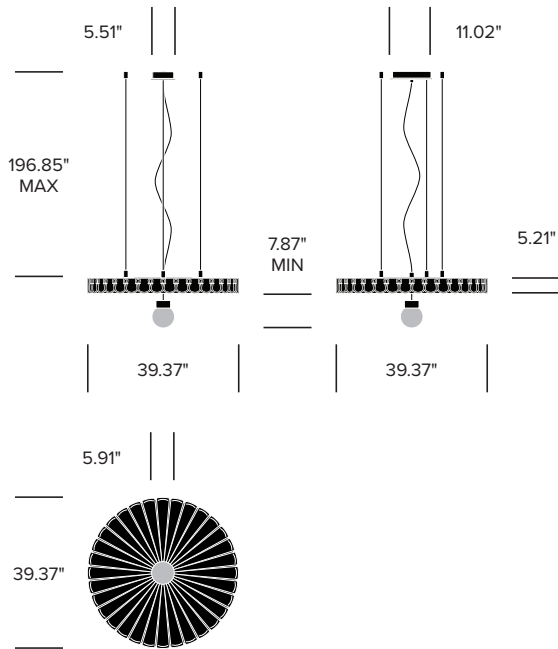

Large Pendant, Ripple

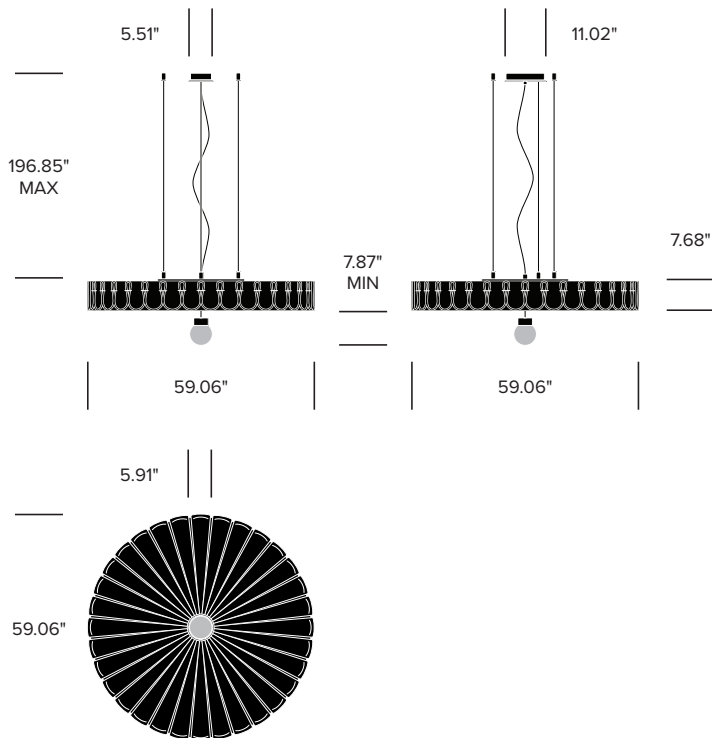

UPHOLSTERY AND FINISHES

Felt

BuzziFelt (BFE)

Lace

Black (BTL-1)
OffWhite (BTL-2)

Cable Trim

Alu (BTR-9006)
Black (BTR-9005)

FEATURES AND SPECIFICATIONS

Voltage:	120V 50/60Hz
Power consumption:	19 watts
Color temperature:	3000K
Luminosity:	1500 lumens
Luminaire efficacy:	79 lumens/watt
Color rendition index:	90 CRI
Rated lifespan:	50,000 hours

All BuzziPleat LED lighting is UL and CE certified.



ACOUSTICS =

Acoustic Principles

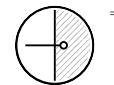

Absorption



Diffusion



Mid Tones



High Tones

BuzziPleat LED

BuzziSpace | 13&9 Design | 2017 | Made in the United States



Medium Pendant, Edel

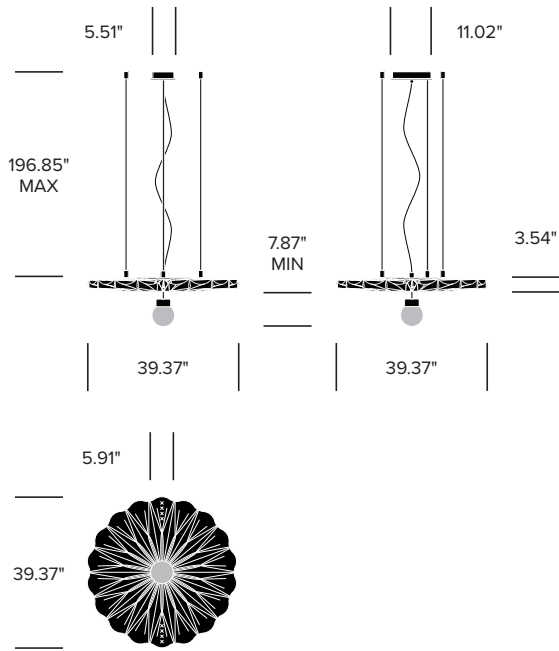

Large Pendant, Edel

