

TECHNICAL SPECIFICATIONS

hushwall HSM-SM-002

HushWall is a customisable, mobile solution that adapts to a variety of office layouts and employee needs. It is a mobile partition wall for a flexible creation of office zones while providing vertical working space.

CASE

- 1 Structure based on lightweight board with aluminium profile nodes.
- 2 Side walls and top and bottom panels made in 38 mm thick honeycomb board.
- 3 Internal construction based on steel profiles.
- 4 60 mm diameter cable grommet located in the top, middle and bottom panels enables cable routing for monitor connection. Maximum weight of screen with bracket 15 kg.

HIDE PANEL

- 5 Made of 18 mm chipboard, melamine double-coated.

ROLLING BASE

- 6 construction based on steel profiles and cast aluminium, powder-coated.
- 7 universal castors for hard and carpeted surfaces with a foot brake.

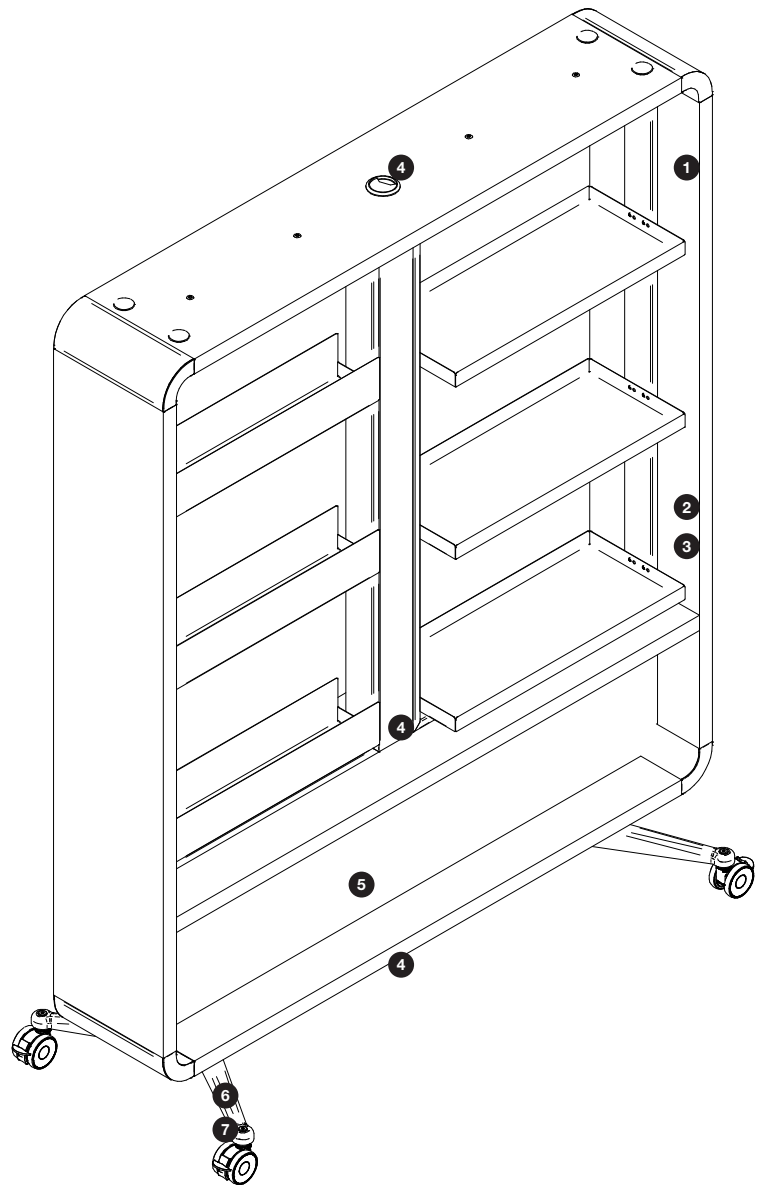

Dimensions (W/D/H): 1600 x 643 x 1993 mm

Net weight: 102-137 kg

Gross weight: 159-203,5 kg

TECHNICAL SPECIFICATIONS

hushwall HSM-SM-002

INTERNAL DIMENSIONS

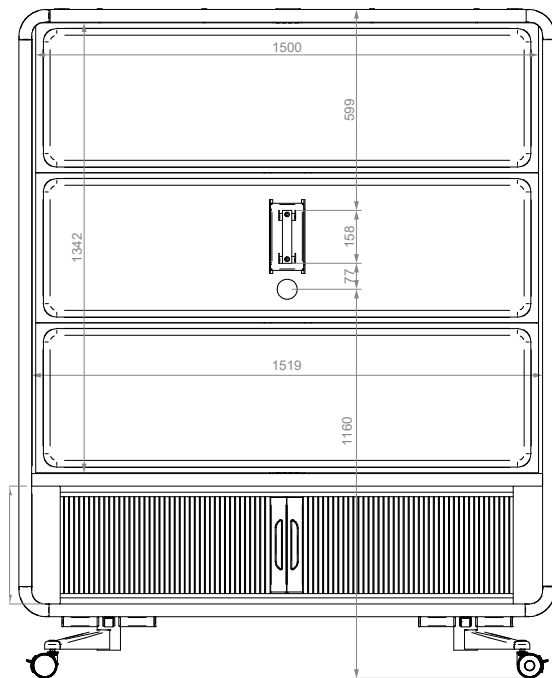
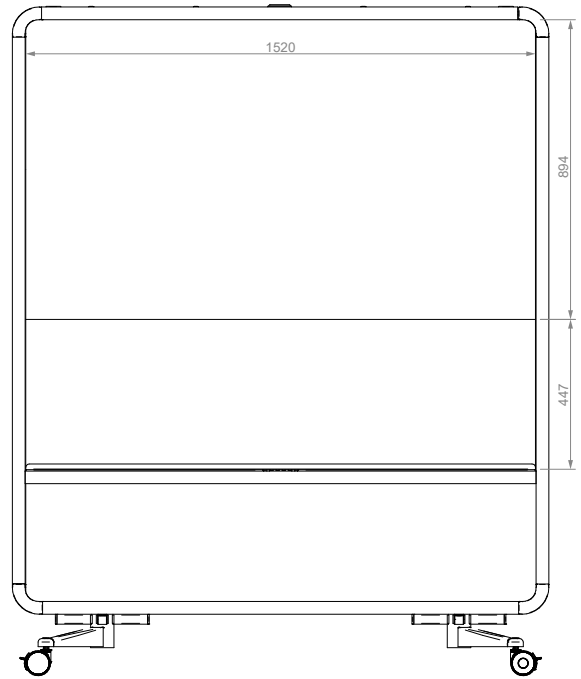
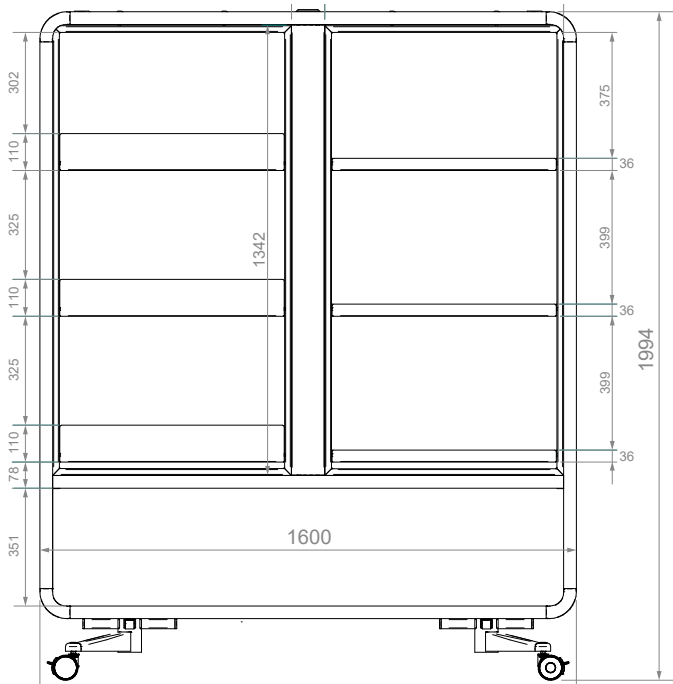

THE CABINET DIMENSIONS

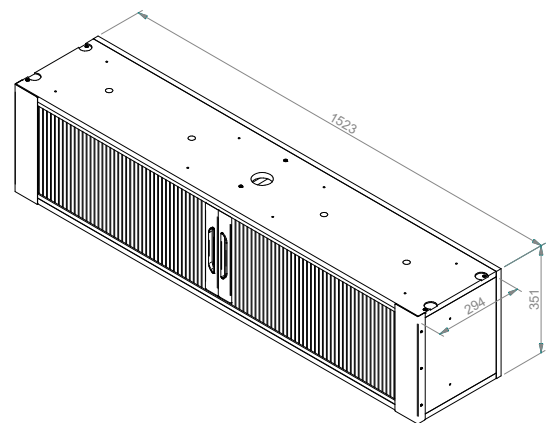

TECHNICAL SPECIFICATIONS

hushwall HSM-SM-002

AVAILABLE CONFIGURATIONS

TWO-SIDED CONFIGURATION

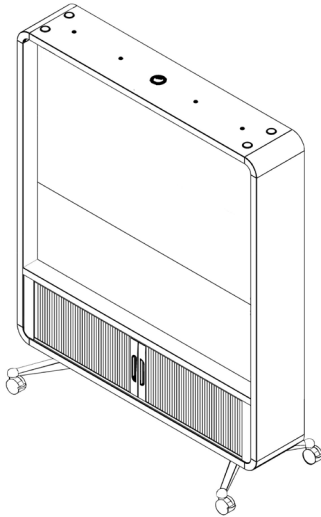

OPTION 1
– dry-wipe board
– cabinet as an option

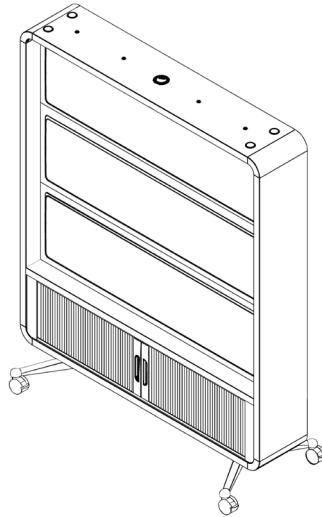

OPTION 2
– upholstered panel
– cabinet as an option

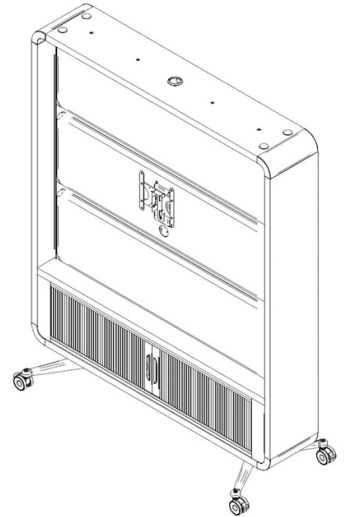

OPTION 3*
– upholstered panel
with possibility of screen mounting
– cabinet as an option
* option available only on single-sided configuration

SINGLE-SIDED CONFIGURATION

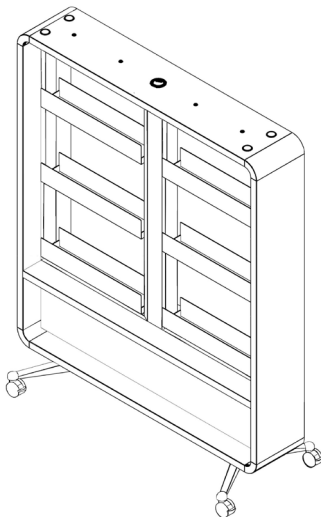

OPTION 1
– pot covers
– cabinet as an option

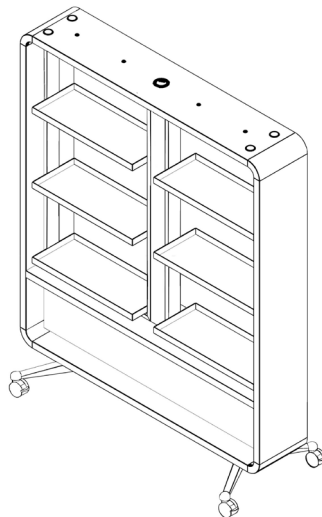

OPTION 2
– shelves
– cabinet as an option

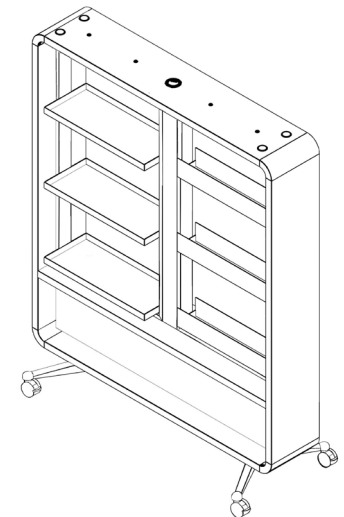

OPTION 3
– pot covers
– shelves
– cabinet as an option

TECHNICAL SPECIFICATIONS

hushwall HSM-SM-002



MATERIAL SPECIFICATIONS

EXTERNAL MATERIALS	38 mm thick, 3-layer honeycomb board, melamine faced on both sides, edges finished using seamless laser technology.
DRY-WIPE BOARD	Made of 18 mm laminated board, coated with a special polyurethane varnish that enables writing on the surface.
VESA BRACKET	VESA (mm) 75 x 75; 100 x 100; 100 x 200; 200 x 100; 200 x 200 with overall dimensions 221 x 226 x 45 mm.
UPHOLSTERED PANELS	Made of thermoformed felt covered with Athlon Plus fabric. UPHOLSTERY Athlon Plus: <ul style="list-style-type: none">· weight: 750 g/m²,· composition: 56% polyester, 44% Trevira CS,· flammability: cigarette (BS EN 1021-1); cigarettes and matches (BS EN 1021 1&2) CA TB 117-2013,· light resistance: 5 (EN ISO 105B02),· pilling resistance: 5 (EN ISO 12945-2),· abrasion resistance: 100.000 martindale cycles (EN ISO 12947-2),· certification: OEKO-TEX® STANDARD 100.



CERTIFICATION



Warranty



Made in EU



SUSTAINABLE DEVELOPMENT

The HushWall partitions are manufactured in the ISO 9001 and 14001 certified production factory in Poland by Mikomax Smart Office. The production process complies with the ISO 14001 environmental management system standard. Hushoffice partitions are packaged and delivered in lightweight, recyclable carton boxes.



hushoffice

Producent: Fabryka Mebli Biurowych Mikomax sp. z o.o. | 93-231 Łódź ul. Dostawcza 4, Polska
Dystrybutor: Mikomax sp. z o.o. | 93-231 Łódź ul. Dostawcza 4, Polska



hushoffice.com