

HAWORTH®

Intuity Parkbench Installation guide



Contents

	Page
• 1. Introduction.....	3
• 2. High table.....	4
• 3. Seating table.....	17
• 4. Sitbench	20

1. Introduction

The following installation guide assumes some knowledge of the installation of Parkbench, this guide will be updated as new elements are released.

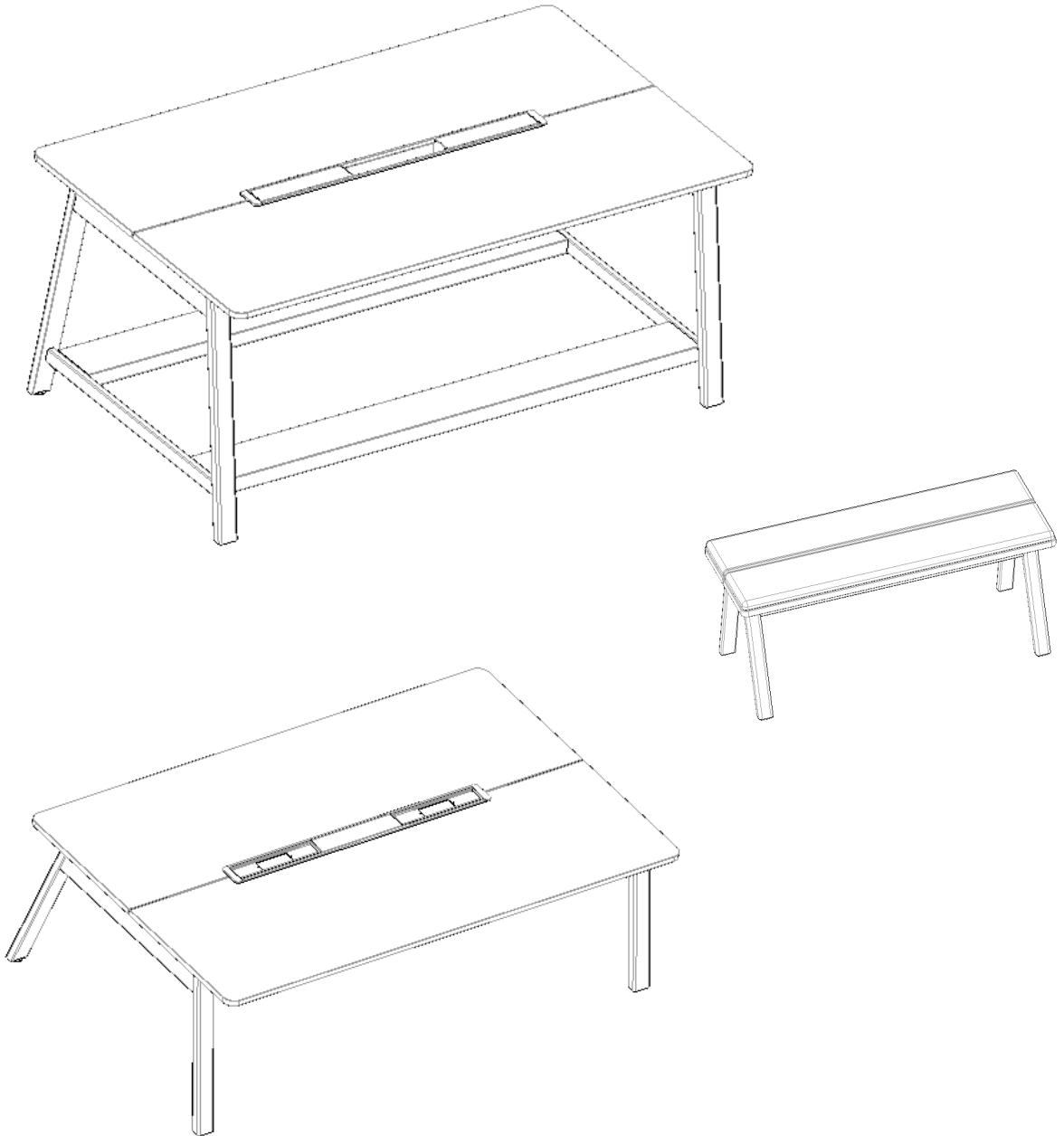

2. High Table

High Table is composed of LH/RH leg, corner bracket, side frame and end frame. High Table installation instruction is as following.

2.1, Install the corner bracket, connector of cross brace and glide with leg together. One table need 2 left legs and 2 right legs.

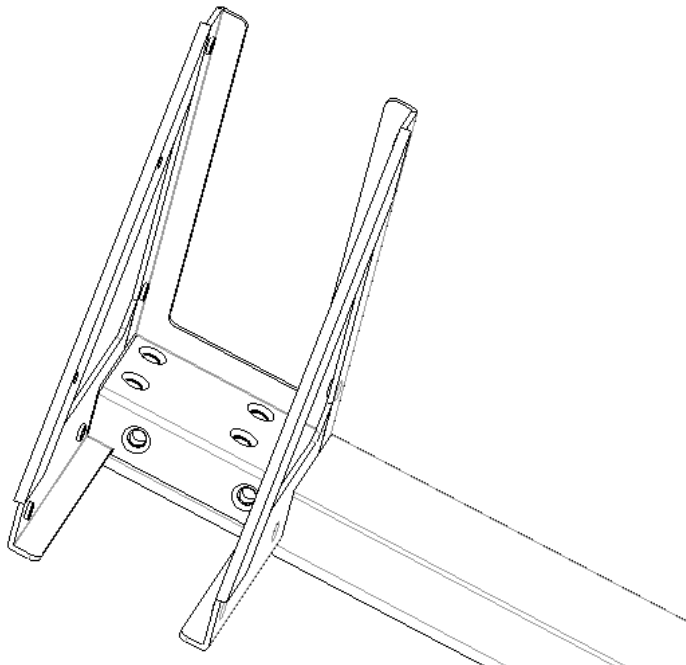
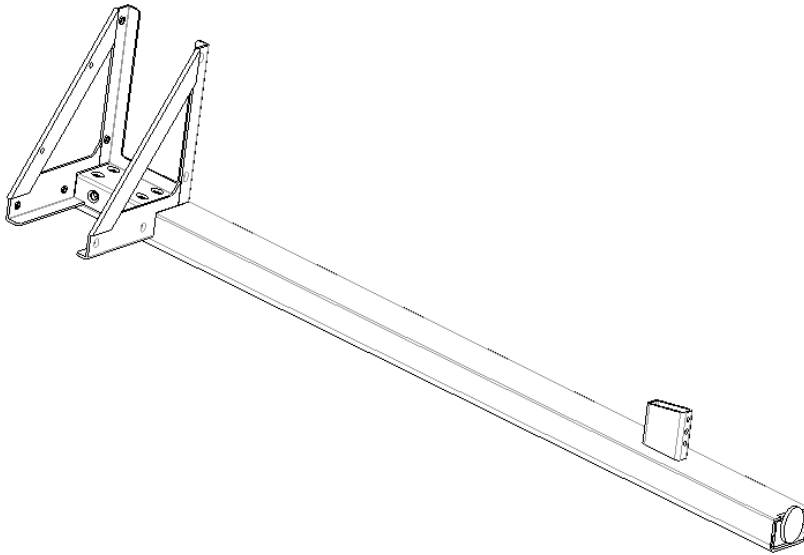

Corner bracket
Screw Spec: M8x25
Screw QTY : 6 pc

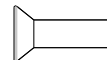

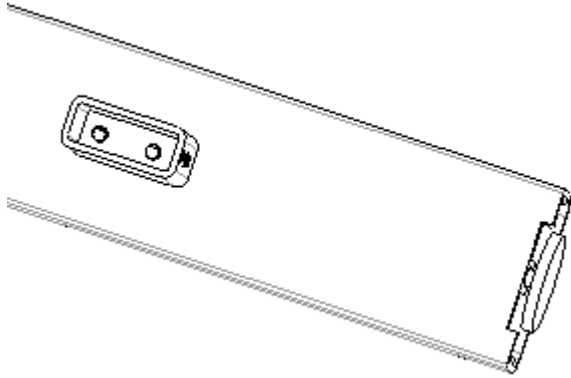

Connector of cross brace
Screw Spec: M6x20
Screw QTY : 2 pc

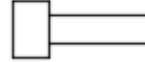

2.2, install the end frame, leg, and cross brace together. Pre-put these components like below shows.

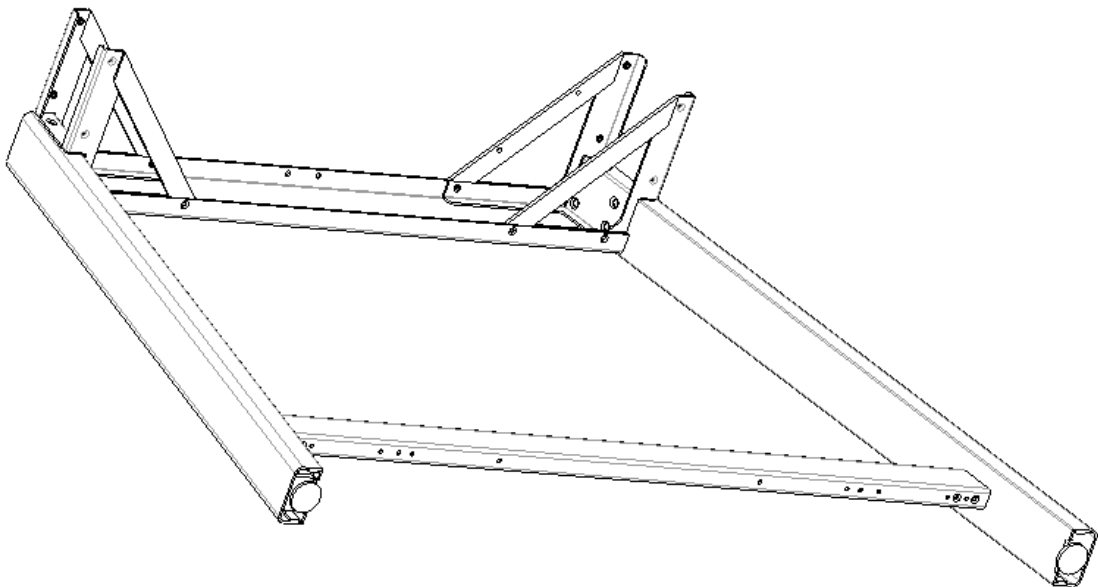

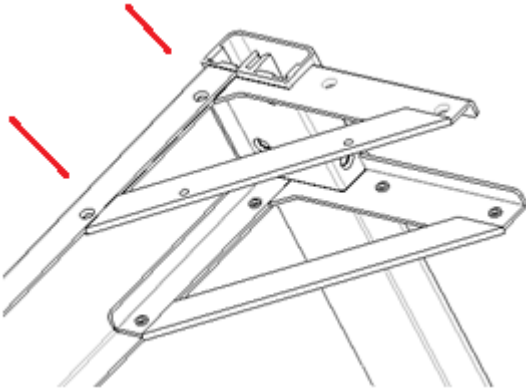

Install leg with end frame

Screw Spec: M6x25

Screw QTY : 4pcs/corner bracket
(2pcs on one side, and 2pcs on the other side)

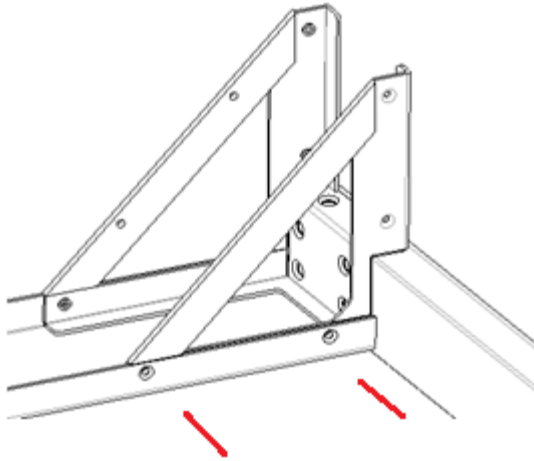
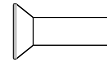

Install leg with cross brace

Screw Spec: M6x25

Screw QTY : 2pcs/ side

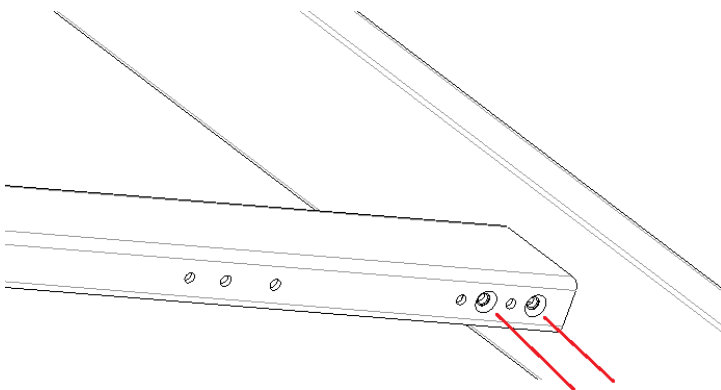
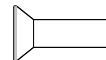

2.3, install leg with side frame. Put the legs and side frames as below shows. The bottom of leg towards up.

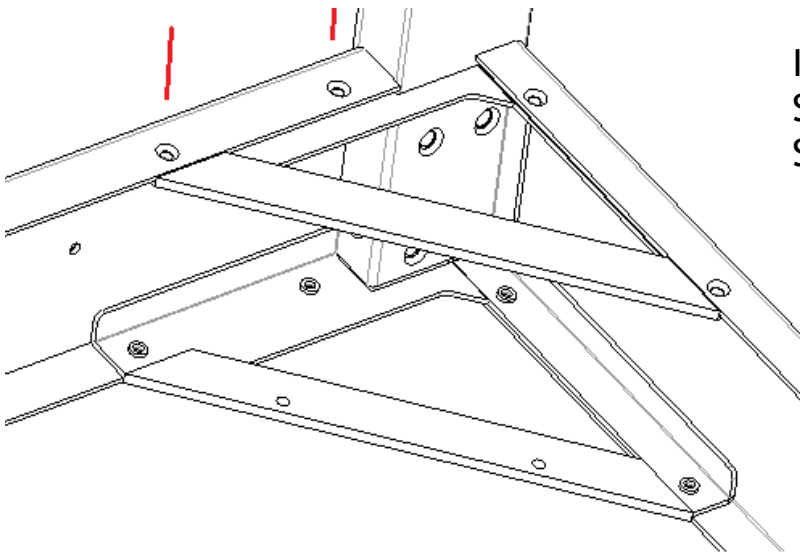
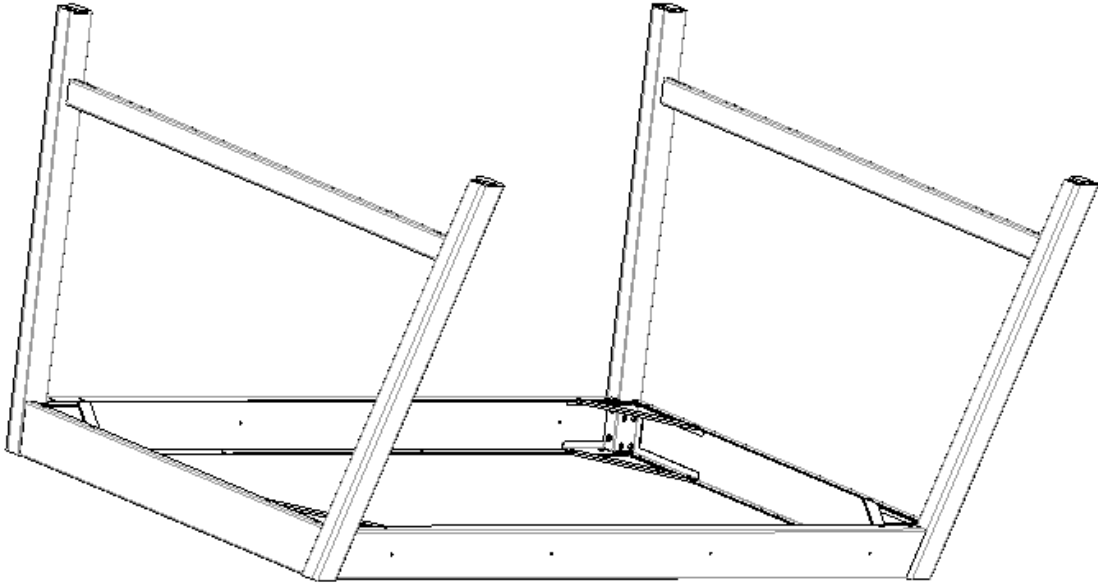

Install side frame
Screw Spec: M6x25
Screw QTY : 2pcs/corner
bracket

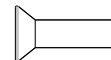

2.4, Install foot rest. If client hasn't ordered, please ignore this step. There are two options for positions of foot rail. Option 1 is outer side, and the other installation position Option 2 is inner side.

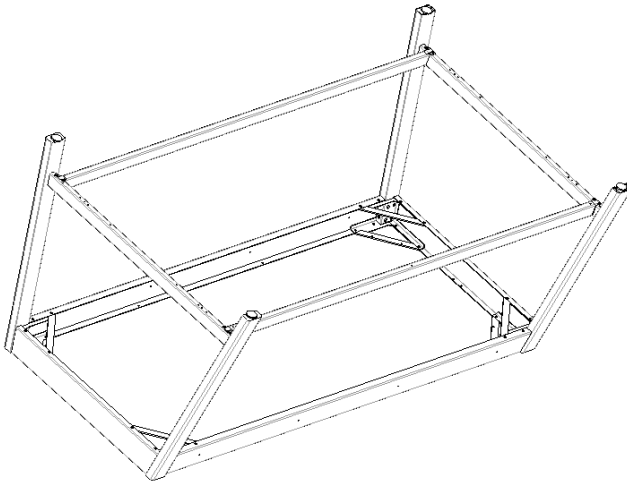

Option 1

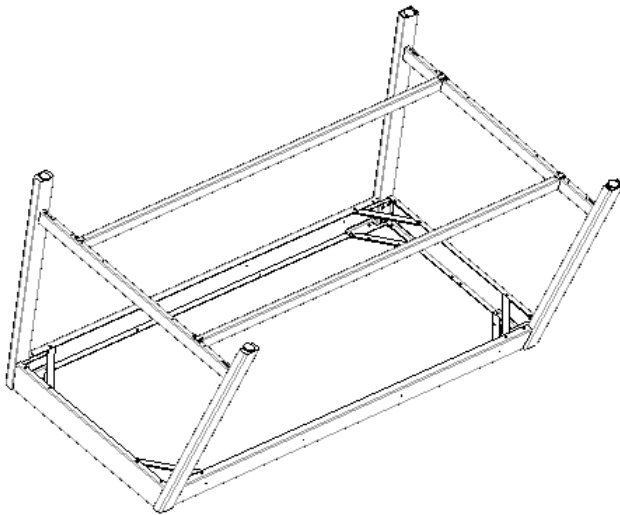

Option 2

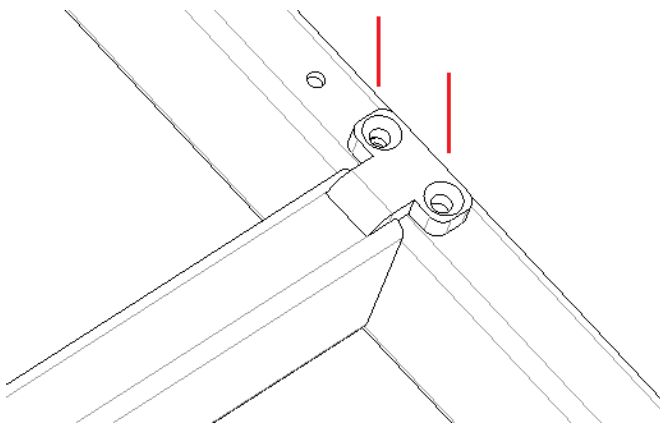

Install foot rest
Screw Spec: M6x25
Screw QTY : 2pcs/side

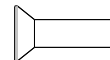

2.5, Install foot rest cover. If client hasn't ordered, please ignore this step. The position is decided by foot rest.

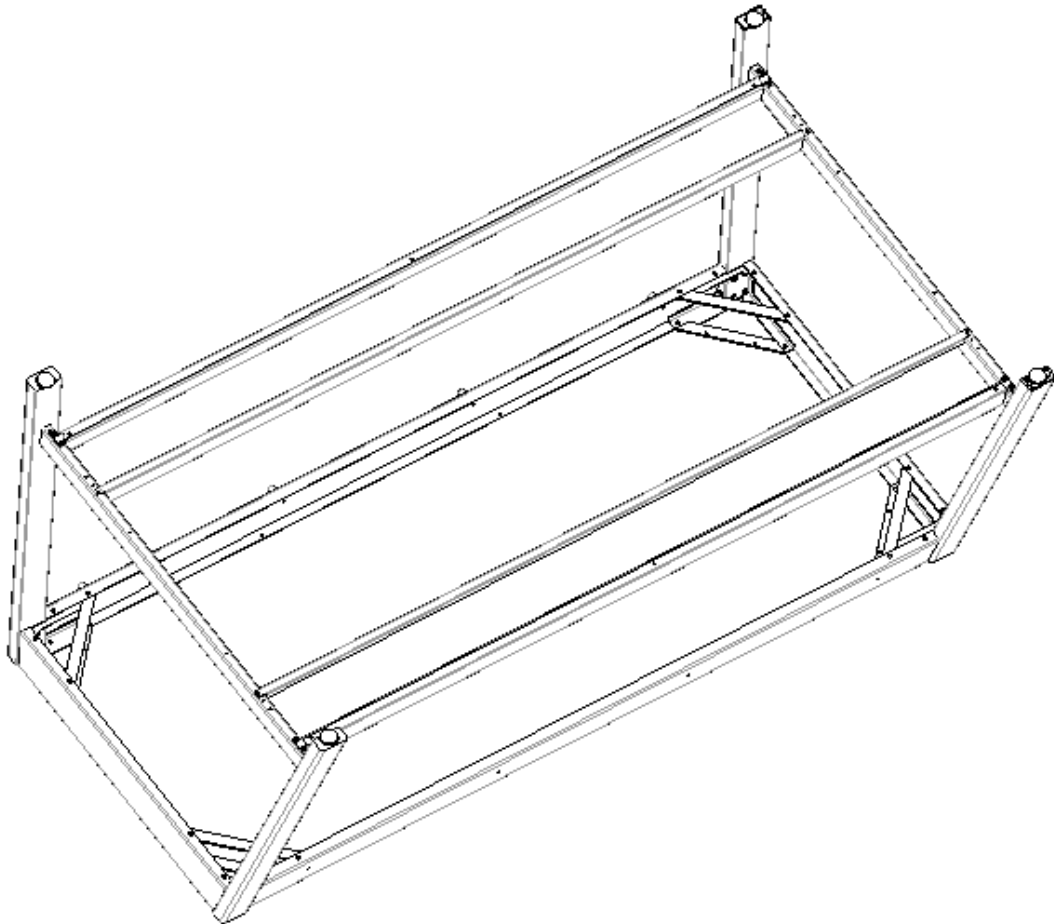

Install foot rest cover
Screw Spec: M6x10
Screw QTY : 5pcs/cover

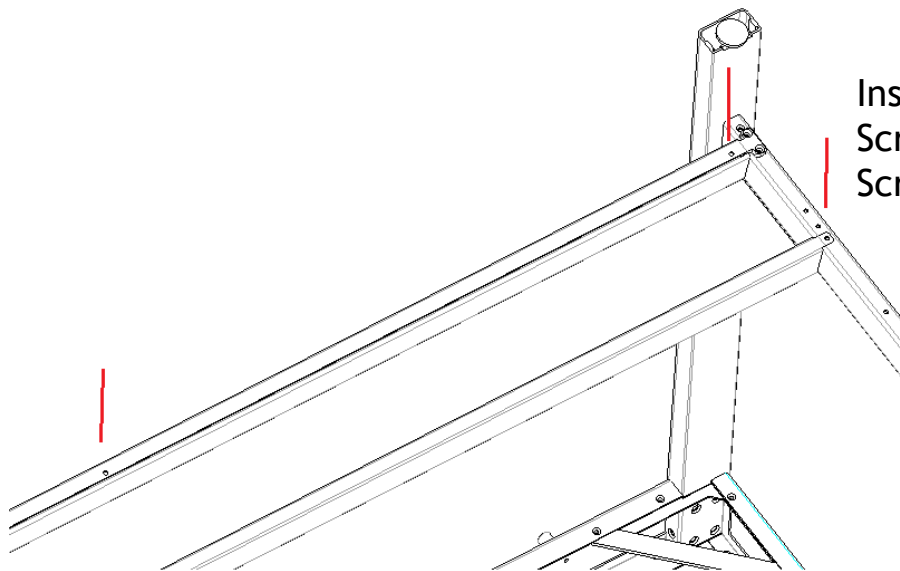

2.6, Turn over whole product to below pic shows. And fix the screws and install the timber hook.

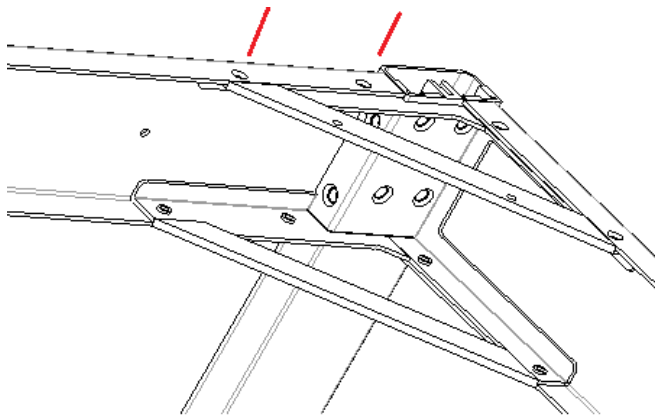
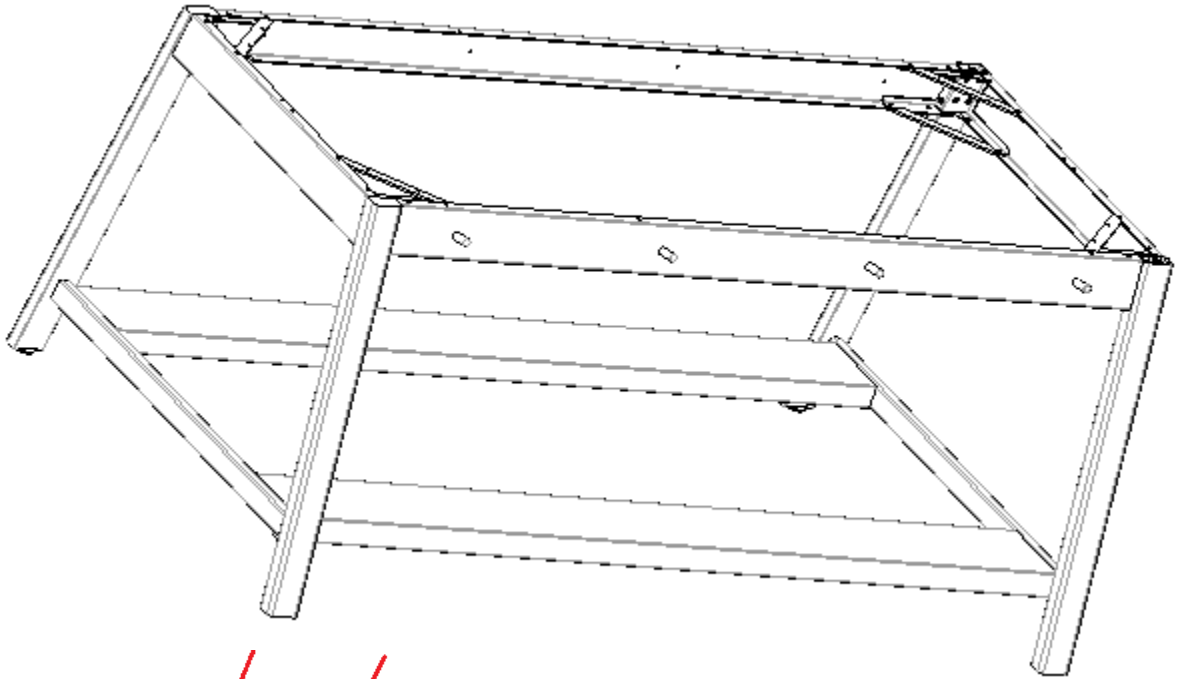

Fix the side frame
Screw Spec: M6x25
Screw QTY : 2pcs/corner bracket

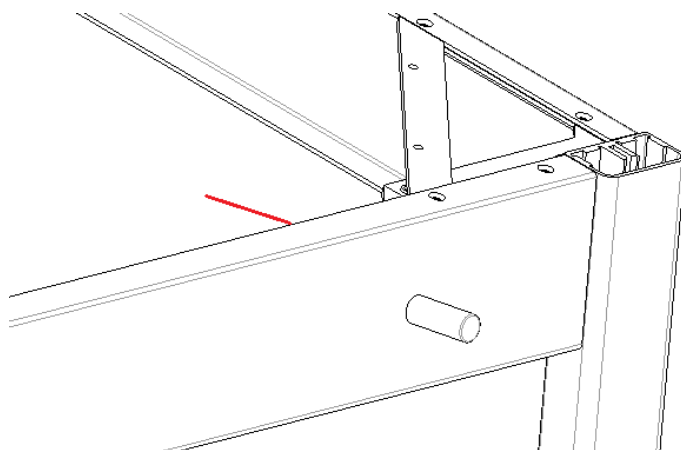
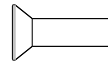

Install timber hook
Screw Spec: ST 4.8X25
Screw QTY : 1pc/Hook



2.7, Install the end cap with central tray together.

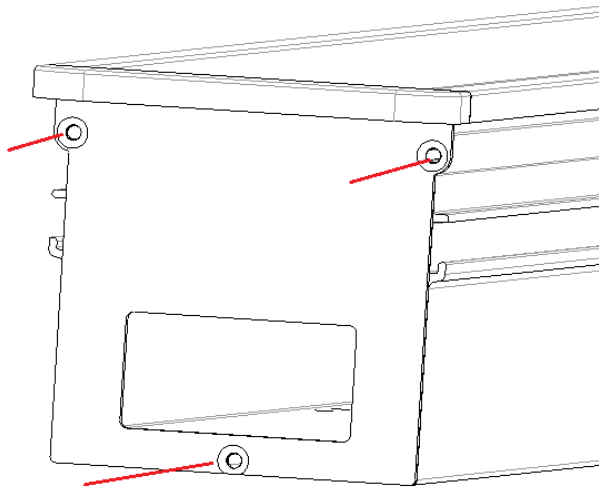
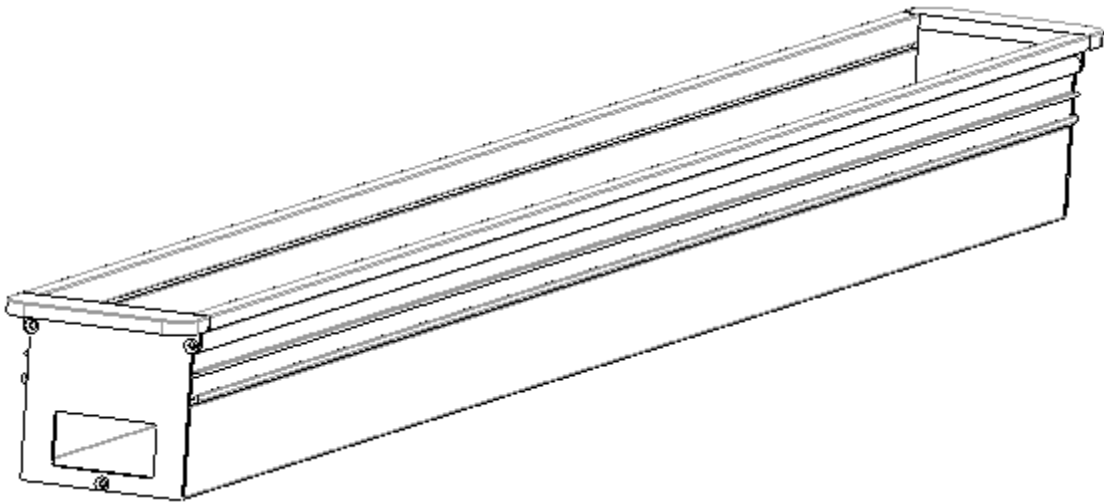

Install the end cap
Screw Spec: M4x10
Screw QTY : 3pcs/side



2.8, Put worktop and central tray on the structure. Fix the worktop and central tray. The gap between two worktops is 5mm.

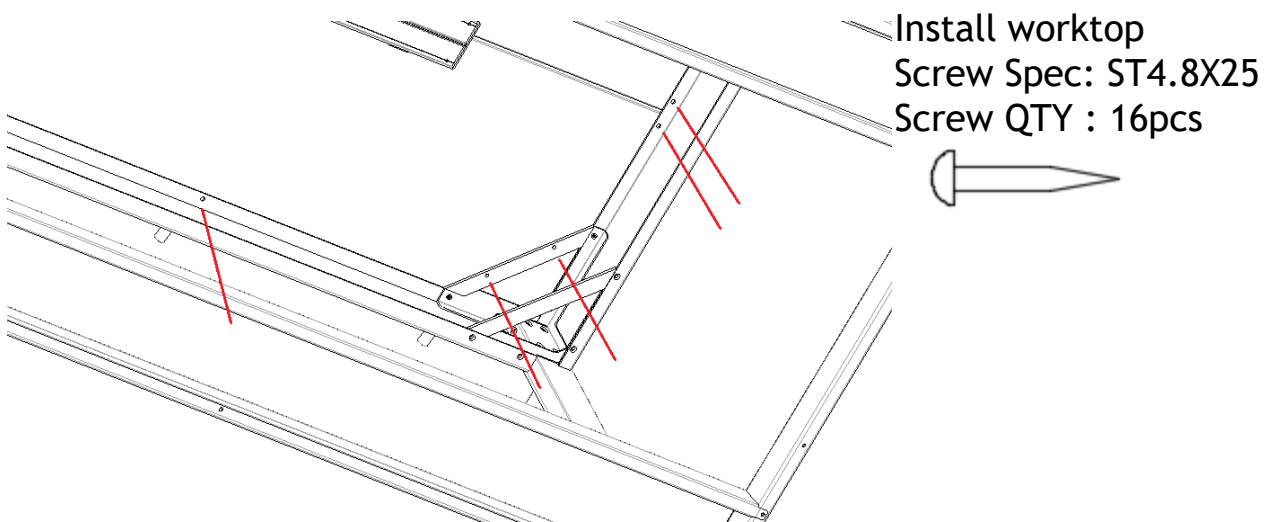
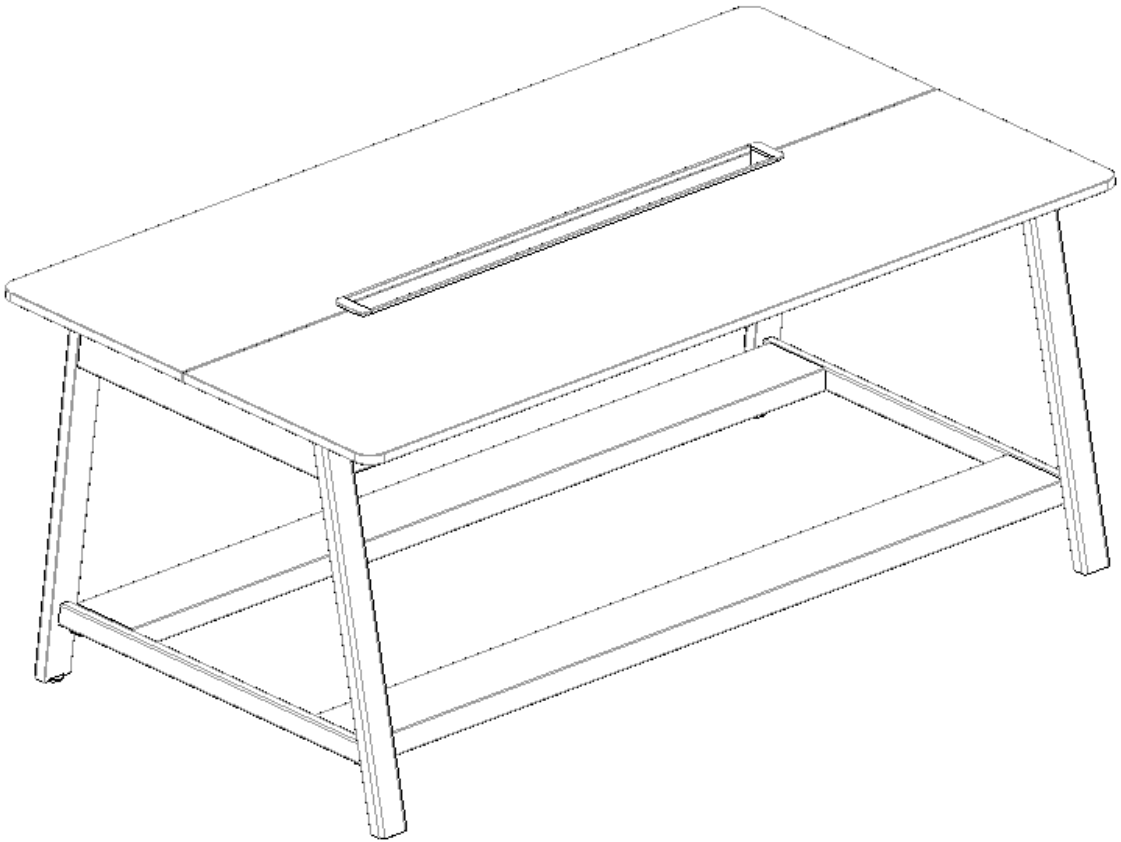

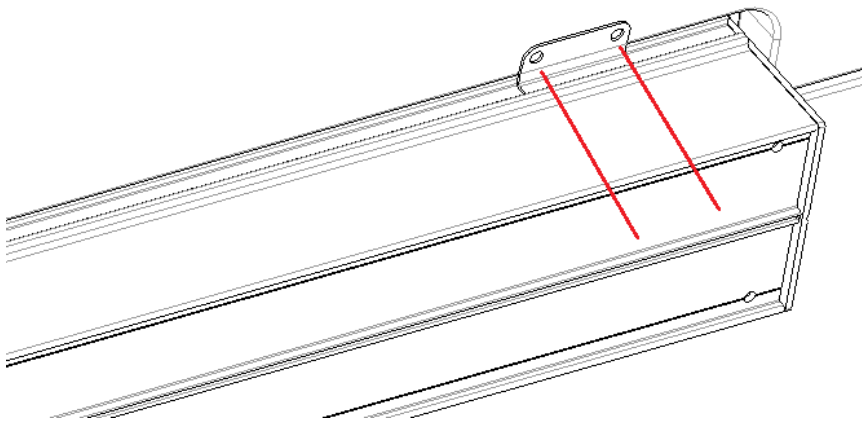
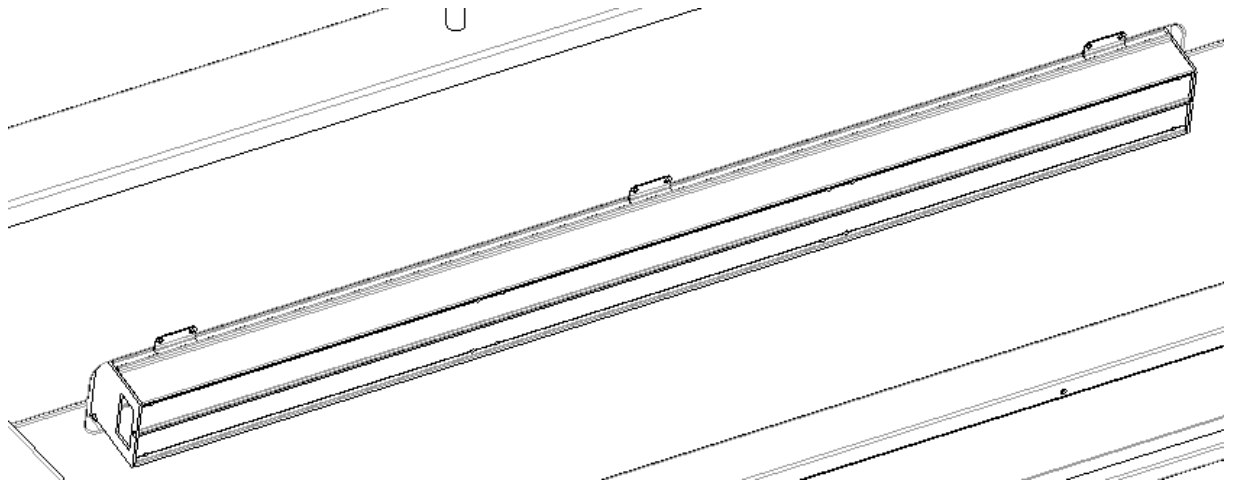

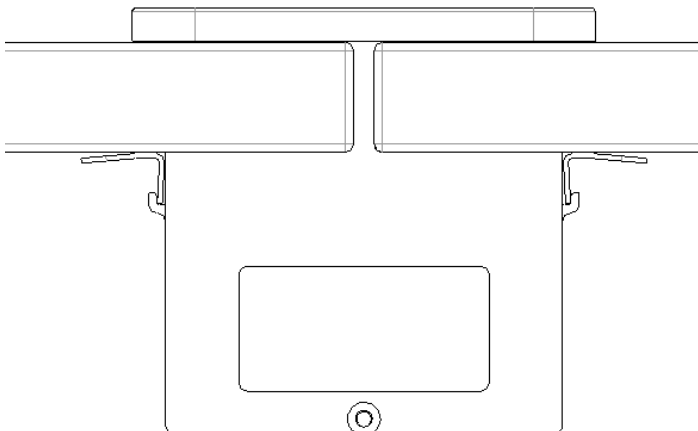

Install central tray
Screw Spec: ST4.2X19
Screw QTY : 2pcs/brk
(the distance between
the brackets should
be about 500mm)

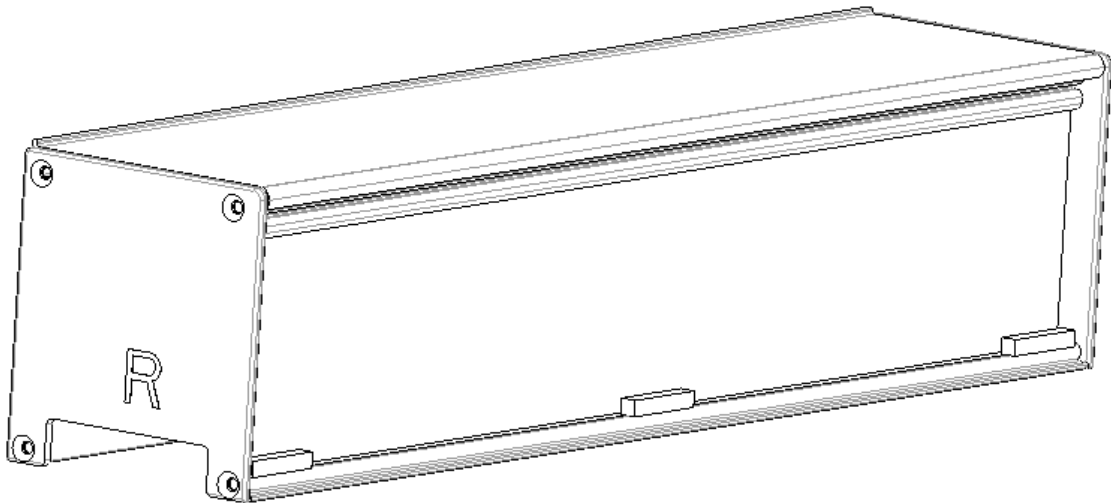
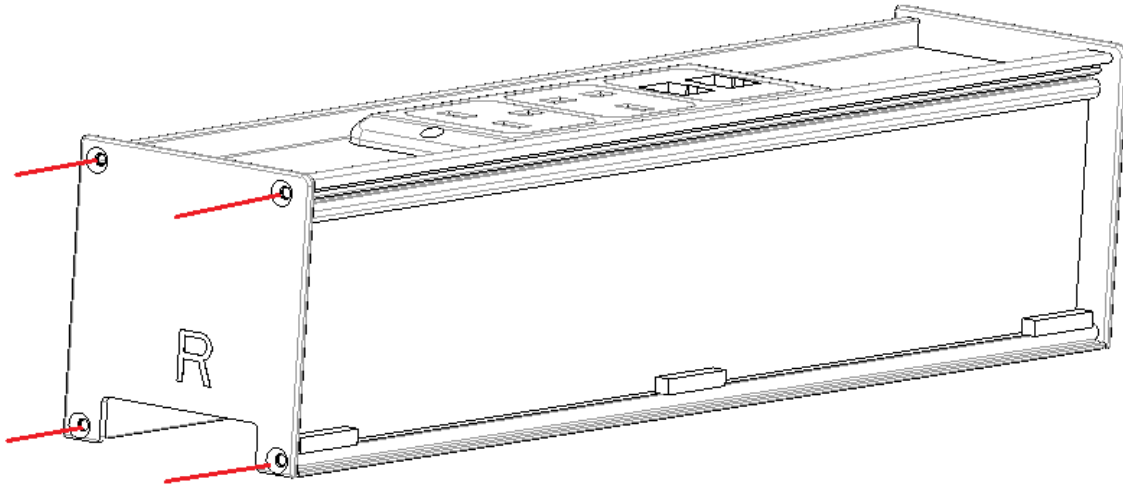

Lateral view for understanding

2.9, Install the socket section



- a, Install the socket, the socket should be purchased separately.
- b, Install the end cap of section,
Screw Spec: M4x10
Screw QTY : 4pcs/side 
- c, Stick 3pcs EVA bumper to section.
- d, Put the flip cover on the section.

2.10, Install the socket section and bottom cover onto central tray.

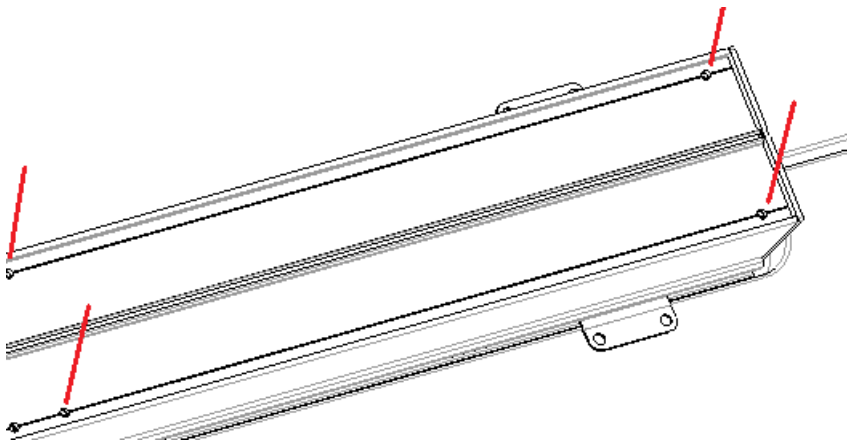
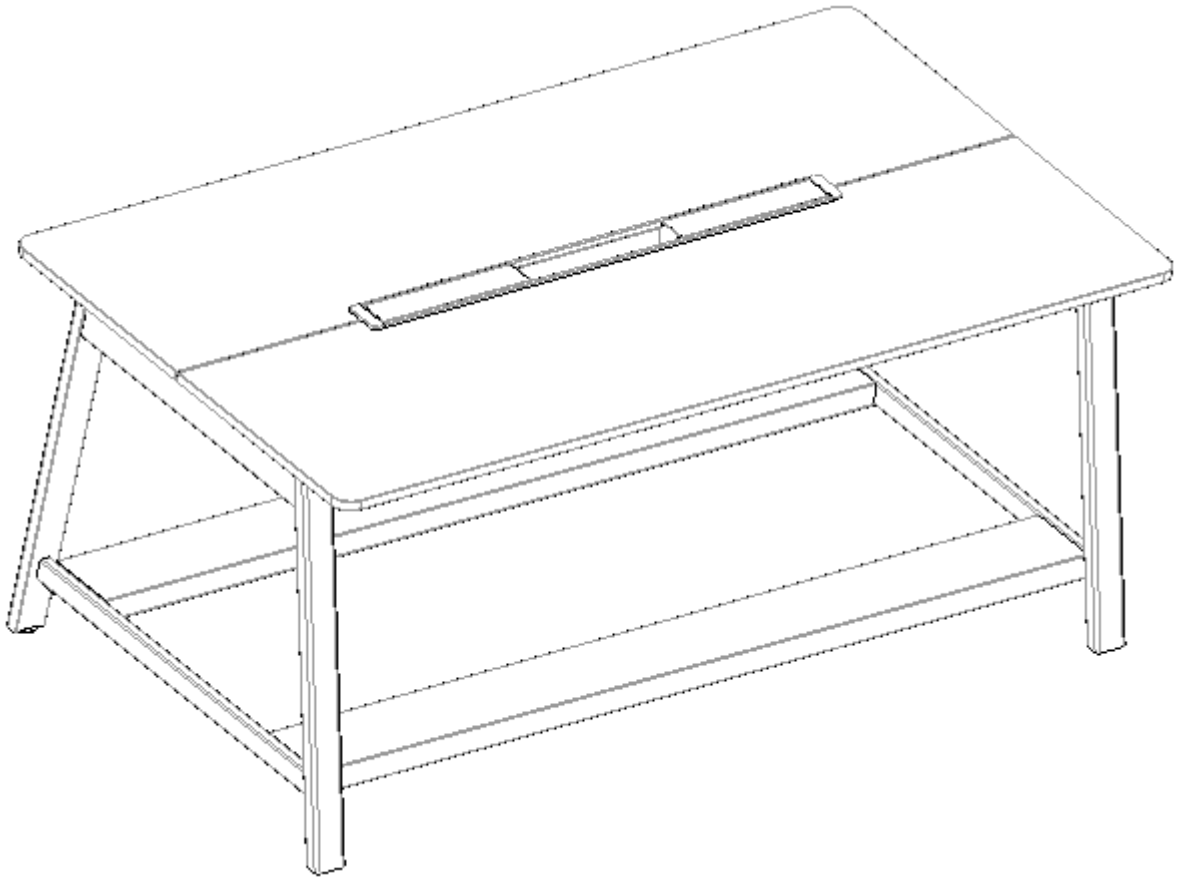

Install the section or
bottom cover
Screw Spec: M5X12
Screw QTY : 12pcs

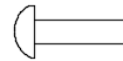

2.11, Install the fabric umbilical cord.

Install top bracket, umbilical cord and bottom bracket together.

Then fix the top bracket with worktop.

Screw Spec: ST4.8X25
Screw QTY : 2pcs

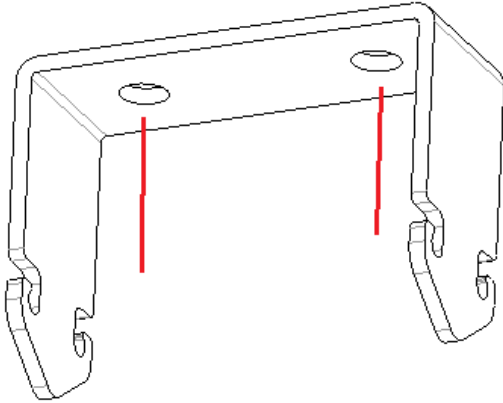

Finish installing.

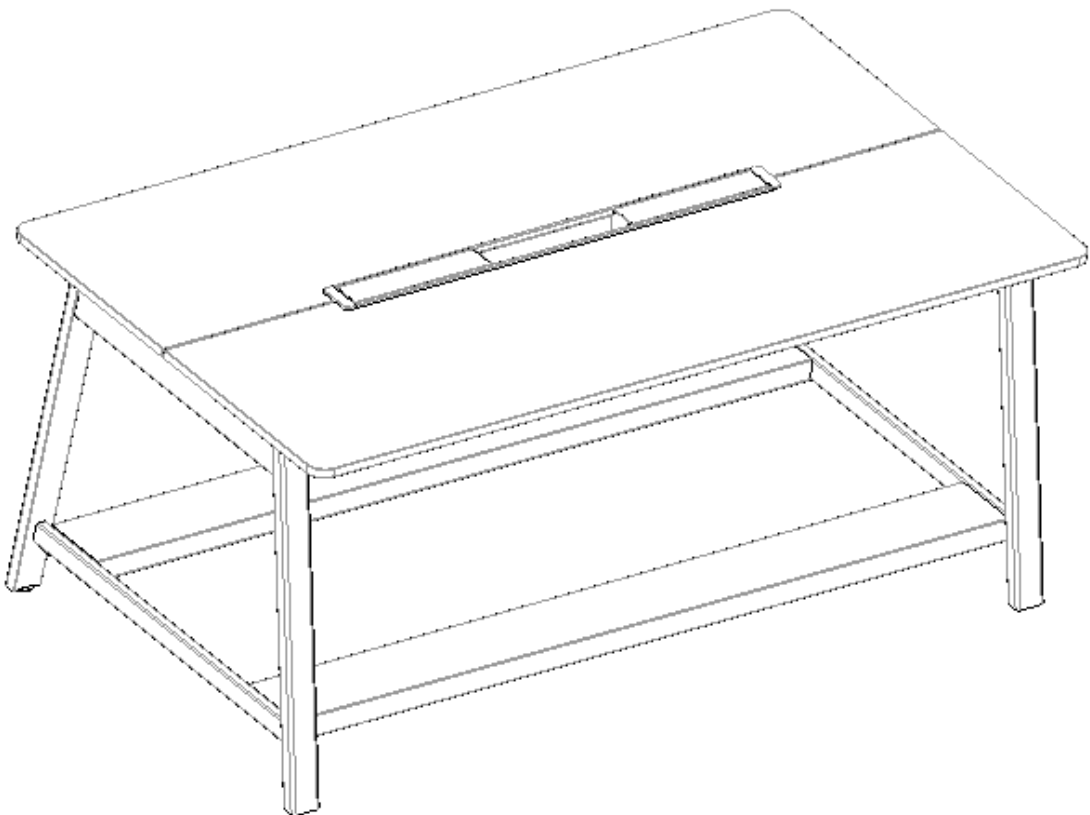

3. Seating table

High table is composed of LH/RH leg, cross beam, main beam and sub beam. Seating table installation instruction is as following.

3.1, Install the cross beam with LH/RH leg together. One table need 2 left legs and 2 right legs. And install the glide.

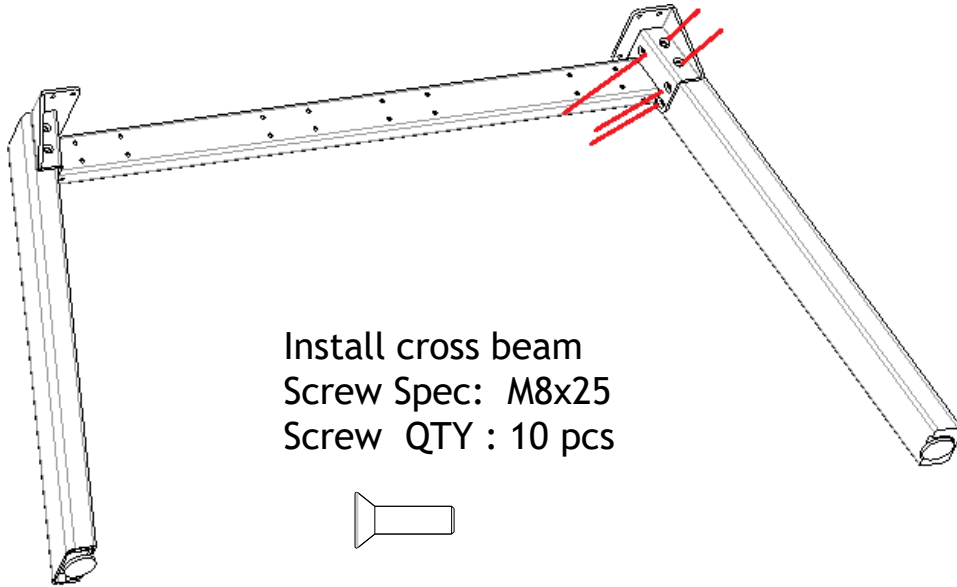

3.2, Install the accent plate.

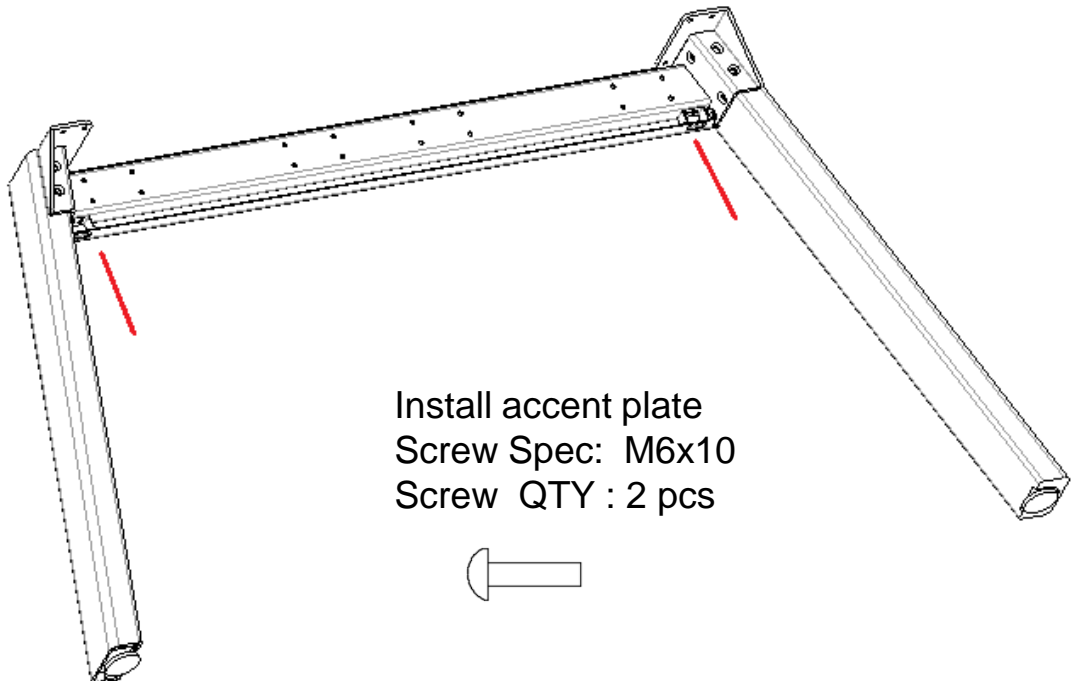

3.3, Install legs with main beams and sub beams together.

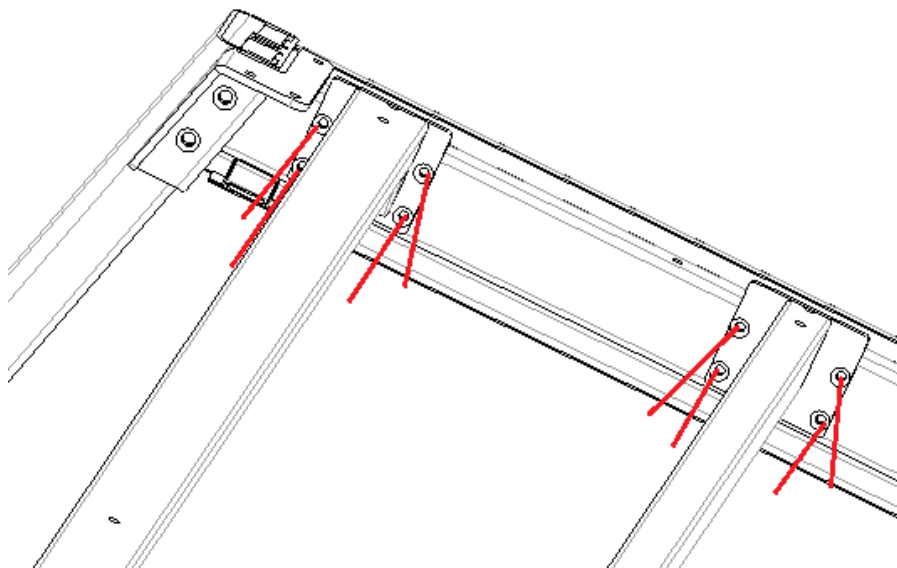
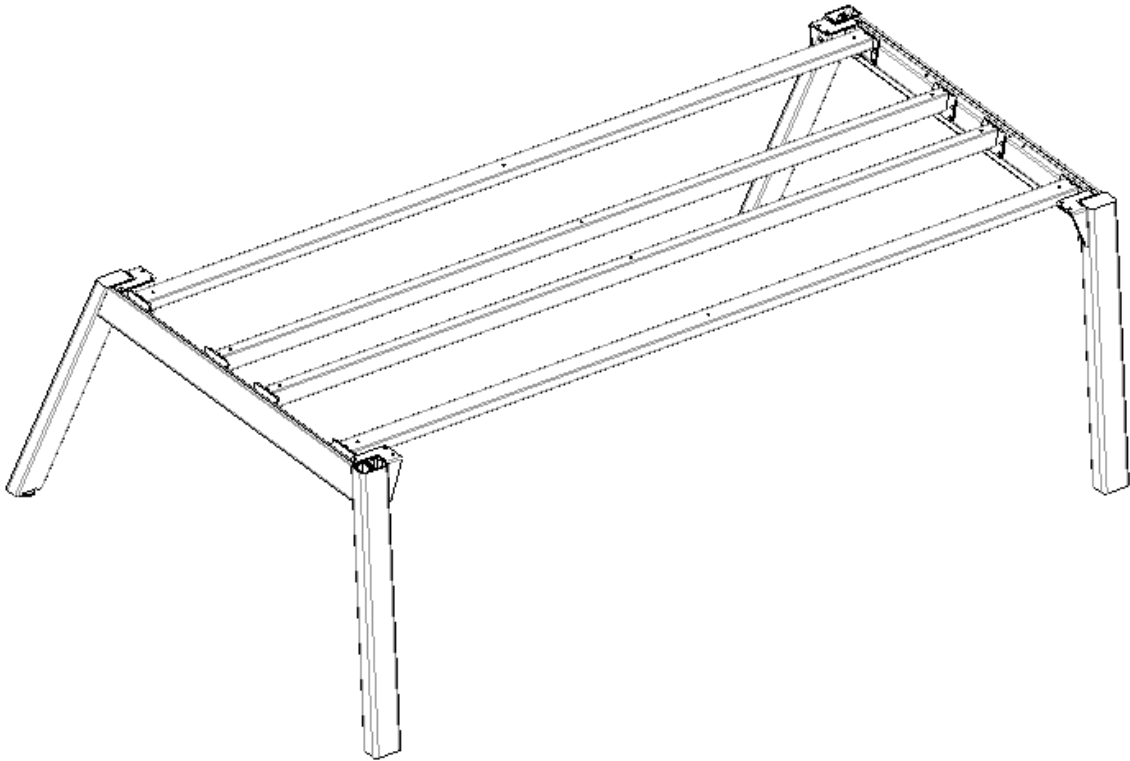

Install beams
Screw Spec: M6x25
Screw QTY : 32 pcs

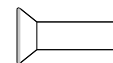

3.4, Install worktop, central tray, socket section and umbilical cord
follow step 2.8 ~ 2.11

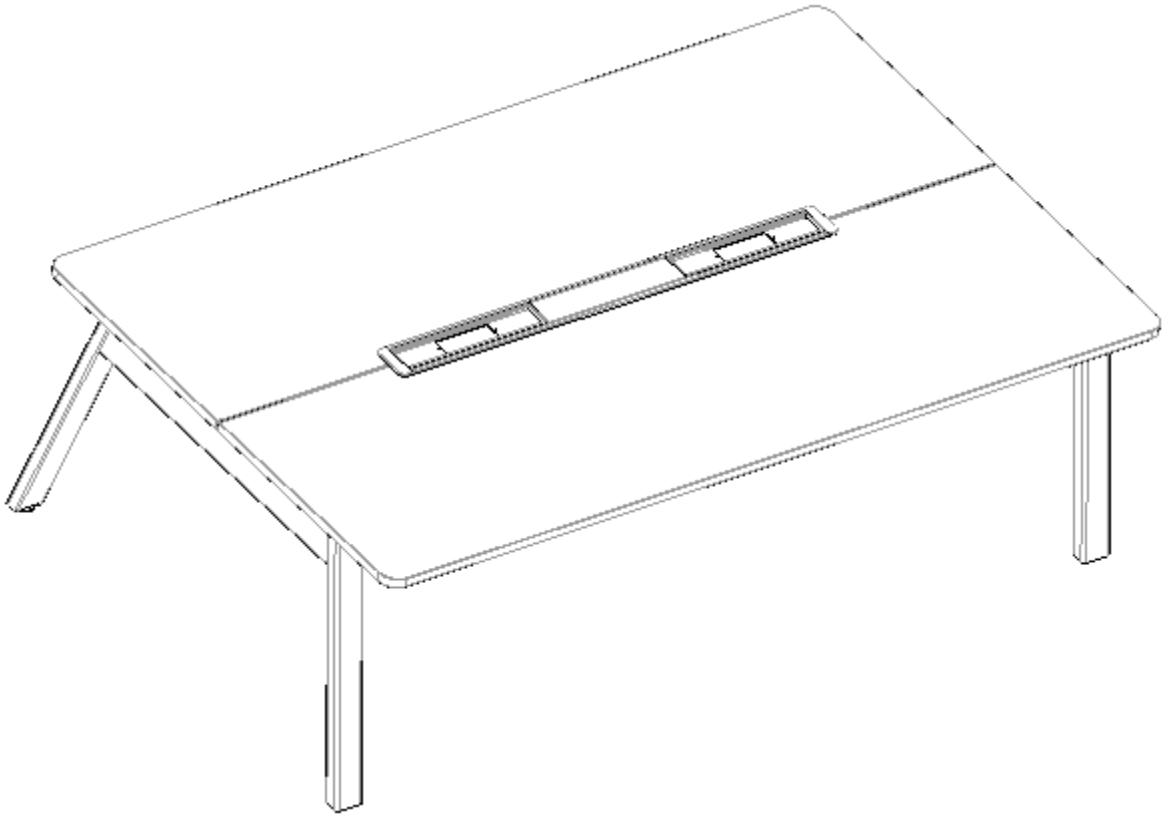

4. Sitbench

Sitbench is composed of LH/RH leg, end frame, side frame, top cushion and cushion bracket. Sitbench installation instruction is as following.

4.1, Install the end frame with LH/RH leg together. One Sitbench need 2 left legs and 2 right legs.

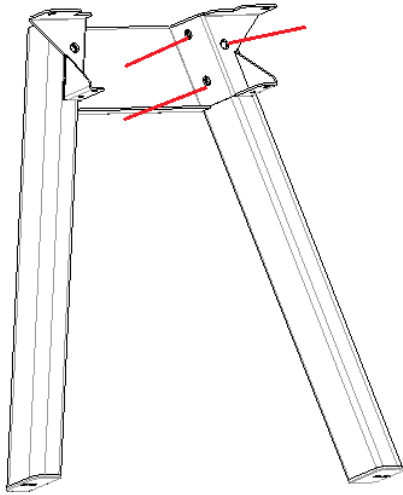

Install end frame
Screw Spec: M6x20
Screw QTY : 6 pcs



4.2, Install the side frame with end frame together.

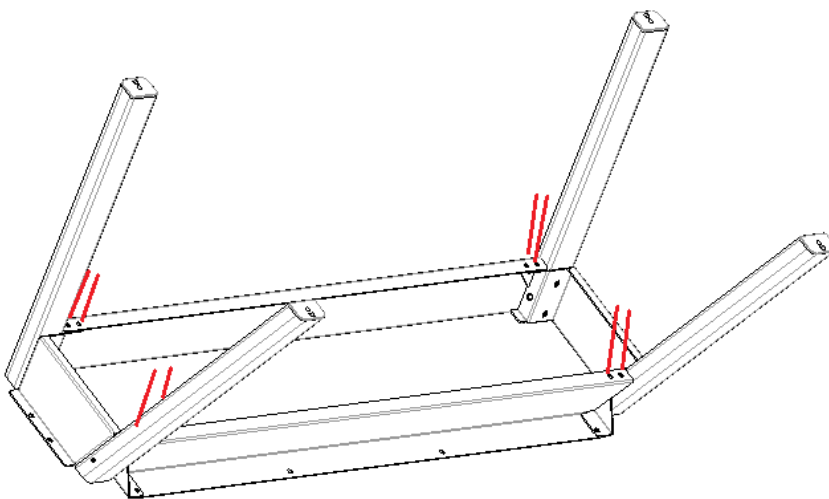

Install side frame
Screw Spec: M6x10
Screw QTY : 8 pcs



4.3, Install top

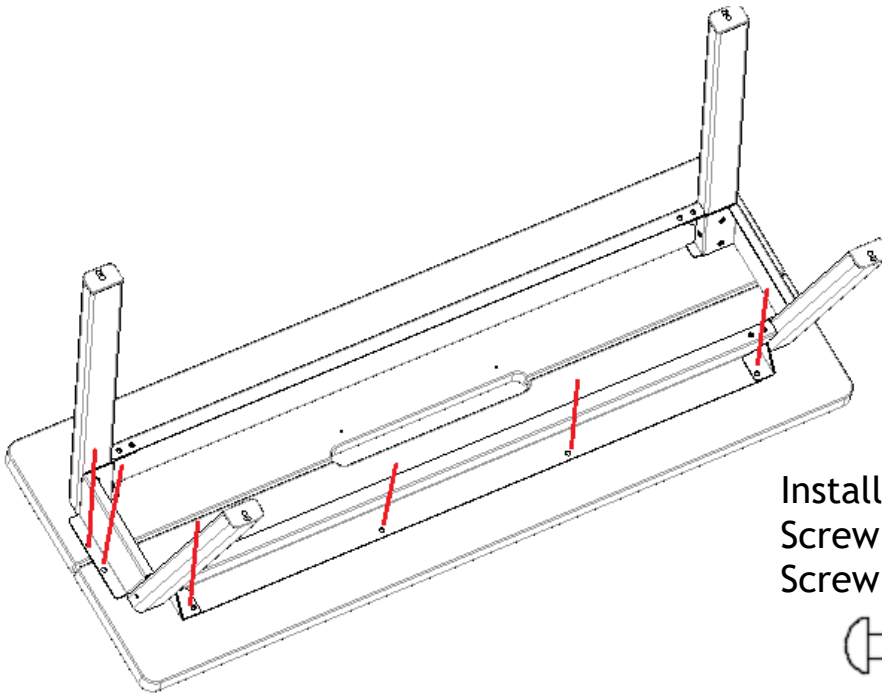

Install top
Screw Spec: ST 4.8X25
Screw QTY : 12 pcs



4.3, Install cushion (optional), put the cushion outside of top, and the cushion bracket on the other side of top. Install the bracket with cushion.

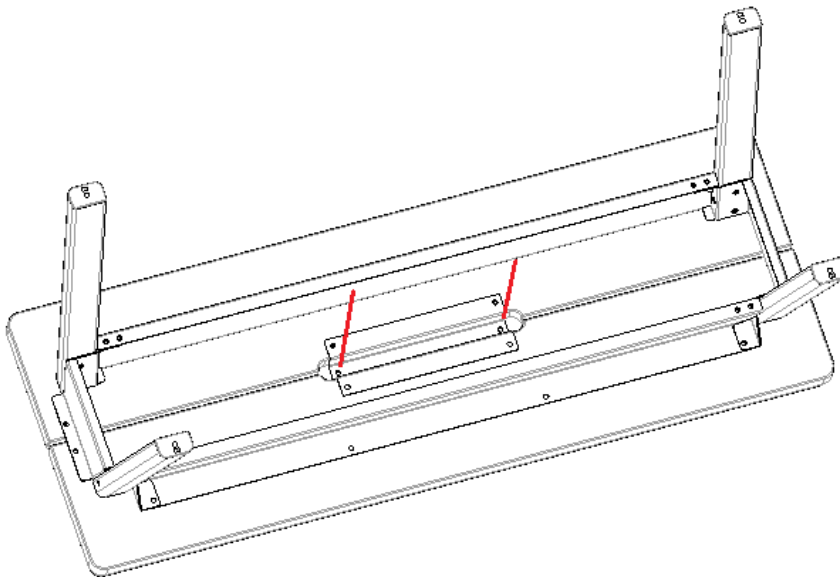

Install side frame
Screw Spec: M6x10
Screw QTY : 2 pcs



4.4, Fix cushion bracket with top.

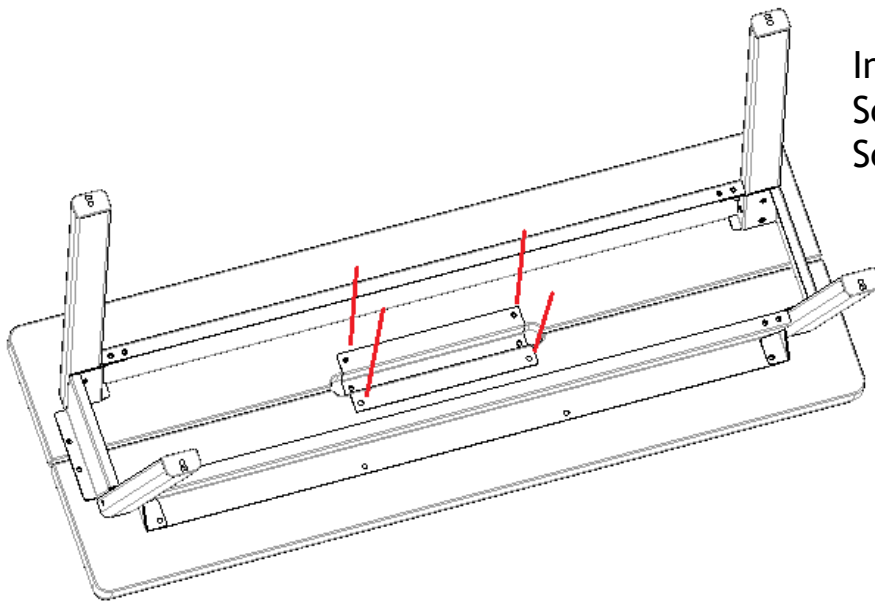

Install top
 Screw Spec: ST 4.8X25
 Screw QTY : 4 pcs

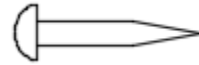

Finish

