

TECHNICAL SPECIFICATION

hushaccess.L HUS-BX-221

SILENCE EASILY ACCESSIBLE

A modular meeting pod is designed for 4-6 people, making it the ideal place to co-create, brainstorm and have meetings. Extremely low doorstep and wider door enable many different meeting arrangements and easy access with a wheelchair. The color schemes fit all styles and make it an ultra-flexible solution for all office spaces.



DIMENSIONING



W/D/H: exterior 102.36 x 106.29 x 87.20 in
interior 93.38 x 103.15 x 82.48 in

Weight: 1825 lbs **Weight with crate:** 2259 lbs
Logistic data is available on request.

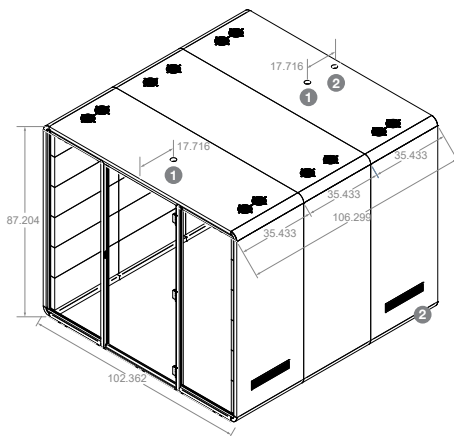

1 Cutout for sprinkler installation 2 Power cable access



ELECTRIFICATION

LED ceiling light.

Power module: UL standard: 2x (power, RJ45, USB Type A 2.4 A, USB Type C 5 A). Black color.

Worktop power module (optional): 3x power hardwired with 13.12 ft lead to US Nema Plug 5.51 in. Black color.

Maximum power consumption of the product 65 W.

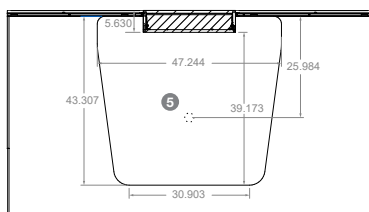

5 Worktop power module (optional)

Power cable: access from ceiling or base (detailed information can be found in the Assembly Manual). 2.36 in opening in the ceiling. White cable with three-prong grounded plug 110V. The total length of the cable – 14.78 ft. The cable length for the exit of unit – 11.82 ft.

RJ45 cable: the total length of the cable – 7.88 ft. The cable length for the exit of unit – 4.60 ft.

Motion sensor: activating lighting and airflow at 100% power. The settings are automatic and do not require adjustment. Located in the ceiling. Standby power consumption 0.3 W.

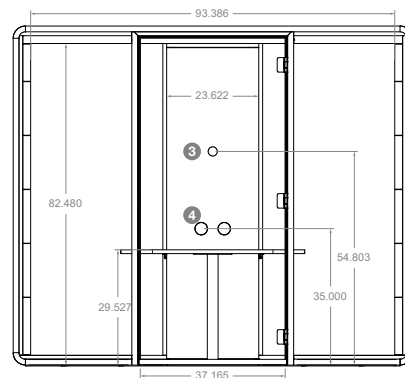

3 Cablepass for screen installation 4 Power modules



LIGHTING

41.4 W/4200 lm. 3000 K. Avg. [lux] 325. Min. [lux]160. Max. [lux] 479.*

* Calculation results of the LED light source on the tabletop inside the booth.
The final amount of Lux depends on the lighting intensity in the office space.



VENTILATION

12 fans. 1837 ft³/h* / 231 seconds**.

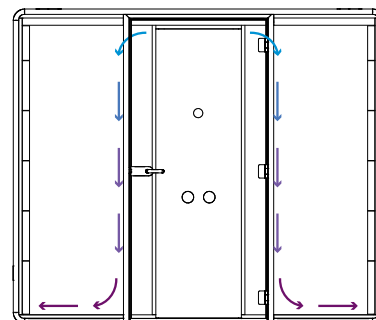

* maximum performance of the single fan, taking into account losses in the ventilation system.
** total time of air change inside based on the volume and capacity of one fan.



hushoffice

Manufacturer: Fabryka Mebli Biurowych Mikomax sp. z o.o. | 93-231 Łódź ul. Dostawcza 4, Polska
Distributor: Mikomax sp. z o.o. | 93-231 Łódź ul. Dostawcza 4, Polska

hushoffice.com

TECHNICAL SPECIFICATION

hushaccess.L HUS-BX-221

EXTERIOR

GLASS DOOR with LATCH HANDLE: acoustic, tempered and laminated safety glass 0.39 in, 5.5.2 thickness including the thickness of 0.19 in glass, 0.07 in acoustic sheet and 0.19 in glass. Clear color.

FRONT AND REAR SIDE GLASS PANELS: acoustic and laminated glass 0.39 in (RW= 35 dB), 5.5.2 thickness including the thickness of 0.19 in glass, 0.07 in acoustic sheet and 0.19 in glass. Placed in aluminum profiles with acoustic seal. Clear color.

PROFILES: for glass and door frame in cosmos grey color.

DOOR HANDLE AND HINGES: anodized aluminum or aluminum painted in cosmos grey color.

CASE: 3-layer honeycomb board with a thickness of 1.49 in. Both sides covered with melamine and finished with ABS edging.

2.50 in hole with grommet for sprinkler installation.

PRODUCT WITHOUT OWN FLOOR (carpet only). 0.1 in aluminum threshold strip. Carpet installation is described in the assembly manual.

INTERIOR

TABLE (optional): (W/D/H) 47.24 x 43.30 x 29.52 in.

Tabletop supported by a metal leg 2.75 in painted in cosmos grey color. Worktop made of 3-layer melamine chipboard, 0.98 in thickness, finished with ABS edging. Finish in non-finger laminate and with power module optional. Maximum load – **15 kg** (33 lbs).

INTERIOR PANELS: high-density LDF (HDF) 0.12 in thickness, covered with non-flammable polyurethane foam. Upholstered.

FLAME RETARDANT FOAM: complies with BS 5852: Part 2: 1982, Ignition source 5 (Crib 5).

UPHOLSTERY Wool:

weight: 325 g/m², **composition:** 70%WO, 20%PL, 5%PA, 5%AF, **flammability:** cigarette and match (BS-EN 1021-1, 2) (BS 5852-0, 1), CAL 117 (class 1), ASTM 84 (class 1), **light fastness:** 5 (EN ISO 105B02), **fastness to rubbing:** wet: 4/5; dry: 4/5 (ISO 105-X12), **abrasion resistance:** 100.000 martindale cycles (EN ISO 12947-2).

CARPET (optional): complies with ASTM D2859 – 16 (2021), standard test method for ignitability characteristics of finished textile floor covering materials. Adapted to commercial intensive use (hotel room, hotel suite, boutique, shop, restaurant, conference room, high traffic office, reception, stairs). Graphite color.

2.36 in hole with grommet for screen installation in standard.

Maximum size of the TV screen that can be installed in the booth: **40"**. Maximum weight of TV set with mount – **15 kg** (33 lbs)

ACOUSTIC RATING

Frequency range 125 Hz to 8000 Hz according to ISO 23351-1:2020. Speech level reduction – $D_{s,A}$ 20.5 (dB).

SEISMIC ANCHORAGE

Product with Seismic Anchoring capability as standard solution. Instructions on how to anchor are available on request.

SUSTAINABILITY

Hushoffice booths are manufactured in a ISO 9001 and 14001 certified production facility in Poland by Mikomax Smart Office. They are compliant with the ISO 14001 Environmental Management System Standard. Hushoffice is packed and delivered in light cardboard boxes which are recycle-friendly.

CERTIFICATION



Warranty



Made in EU



Premium wool
CAL 117



Certificates



hushoffice

Manufacturer: Fabryka Mebli Biurowych Mikomax sp. z o.o. | 93-231 Łódź ul. Dostawcza 4, Polska
Distributor: Mikomax sp. z o.o. | 93-231 Łódź ul. Dostawcza 4, Polska

hushoffice.com